



20



312en20

## REFLECTION AND REFRACTION OF LIGHT

Light makes us to see things and is responsible for our visual contact with our immediate environment. It enables us to admire and adore various beautiful manifestations of mother nature in flowers, plants, birds, animals, and other forms of life. Can you imagine how much shall we be deprived if we were visually impaired? Could we appreciate the brilliance of a diamond or the majesty of a rainbow? Have you ever thought how light makes us see? How does it travel from the sun and stars to the earth and what is it made of? Such questions have engaged human intelligence since the very beginning. You will learn about some phenomena which provide answers to such questions.

Look at light entering a room through a small opening in a wall. You will note the motion of dust particles, which essentially provide simple evidence that light travels in a straight line. An arrow headed straight line represents the direction of propagation of light and is called a ray; a collection of rays is called a **beam**. The ray treatment of light constitutes **geometrical optics**. In lesson 22, you will learn that light behaves as a wave. But a wave of short wavelength can be well approximated by the ray treatment. When a ray of light falls on a mirror, its direction changes. This process is called *reflection*. But when a ray of light falls at the boundary of two dissimilar surfaces, it bends. This process is known as *refraction*. You will learn about reflection from mirrors and refraction from lenses in this lesson. You will also learn about *total internal reflection*. These phenomena find a number of useful applications in daily life from automobiles and health care to communication.



### OBJECTIVES

After studying this lesson, you should be able to:

- explain reflection at curved surfaces and establish the relationship between the focal length and radius of curvature of spherical mirrors;



Notes

- state sign convention for spherical surfaces;
- derive the relation between the object distance, the image distance and the focal length of a mirror as well as a spherical refractive surface;
- state the laws of refraction;
- explain total internal reflection and its applications in everyday life;
- derive Newton's formula for measuring the focal length of a lens;
- describe displacement method to find the focal length of a lens; and
- derive an expression for the focal length of a combination of lenses in contact.

### 20.1 REFLECTION OF LIGHT FROM SPHERICAL SURFACES

In your earlier classes, you have learnt the laws of reflection at a plane surface. Let us recall these laws :

**Law 1** –The incident ray, the reflected ray and the normal to the reflecting surface at the point of incidence always lie in the same plane.

**Law 2** –The angle of incidence is equal to the angle of reflection :

$$\angle i = \angle r$$

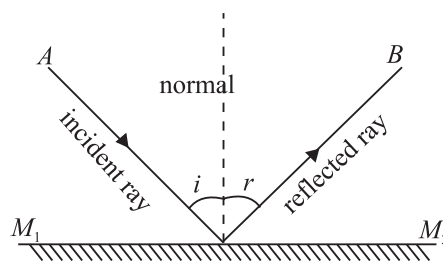

Fig. 20.1 : Reflection of light from a plane surface

These are illustrated in Fig. 20.1. Though initially stated for plane surfaces, these laws are also true for spherical mirrors. This is because a spherical mirror can be regarded as made up of a large number of extremely small plane mirrors. A well-polished spoon is a familiar example of a spherical mirror. Have you seen the image of your face in it? Fig. 20.2(a) and 20.2 (b) show two main types of spherical mirrors.

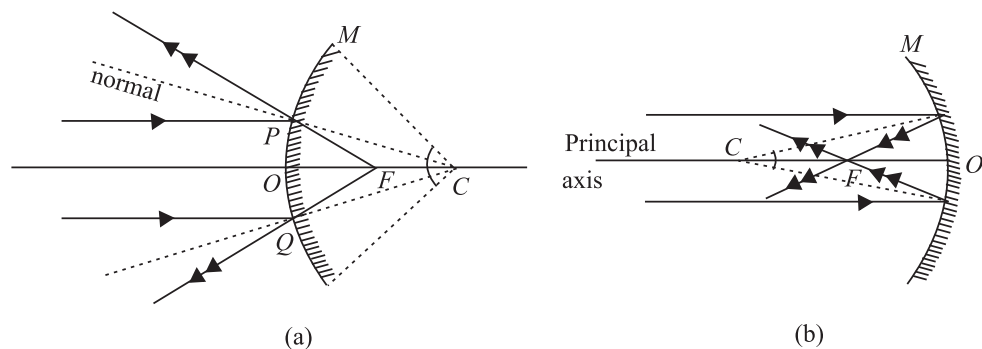

Fig. 20.2 : Spherical mirrors : a) a convex mirror, and b) a concave mirror

Note that the reflecting surface of a convex mirror curves outwards while that of a concave mirror curves inwards. We now define a few important terms used for spherical mirrors.

The centre of the sphere, of which the mirror is a part, is called the **centre of curvature** of the mirror and the radius of this sphere defines its **radius of curvature**. The middle point  $O$  of the reflecting surface of the mirror is called its **pole**. The straight line passing through  $C$  and  $O$  is said to be the **principal axis** of the mirror. The circular outline (or periphery) of the mirror is called its **aperture** and the angle ( $\angle MCM'$ ) which the aperture subtends at  $C$  is called the **angular aperture** of the mirror. Aperture is a measure of the size of the mirror.

A beam of light incident on a spherical mirror parallel to the principal axis converges to or appears to diverge from a common point after reflection. This point is known as **principal focus** of the mirror. The distance between the pole and the principal focus gives the **focal length** of the mirror. A plane passing through the focus perpendicular to the principal axis is called the **focal plane**.

We will consider only small aperture mirrors and rays close to the principal axis, called **paraxial rays**. (The rays away from the principal axis are called **marginal** or **parapheral rays**.)



### INTEXT QUESTIONS 20.1

- Answer the following questions :
  - Which mirror has the largest radius of curvature : plane, concave or convex?
  - Will the focal length of a spherical mirror change when immersed in water?
  - What is the nature of the image formed by a plane or a convex mirror?
  - Why does a spherical mirror have only one focal point?
- Draw diagrams for concave mirrors of radii 5cm, 7cm and 10cm with common centre of curvature. Calculate the focal length for each mirror. Draw a ray parallel to the common principal axis and draw reflected rays for each mirror.
- The radius of curvature of a spherical mirror is 30cm. What will be its focal length if (i) the inside surface is silvered? (ii) outside surface is silvered?
- Why are dish antennas curved?

#### 20.1.1 Ray Diagrams for Image Formation

Let us again refer to Fig. 20.2(a) and 20.2(b). You will note that

- the ray of light through centre of curvature retraces its path.



Notes



Notes

- the ray of light parallel to the principal axis, on reflection, passes through the focus; and
- the ray of light through  $F$  is reflected parallel to the principal axis.

To locate an image, any two of these three rays can be chosen. The images are of two types : real and virtual.

**Real image** of an object is formed when reflected rays actually intersect. These images are inverted and can be projected on a screen. They are formed on the same side as the object in front of the mirror (Fig. 20.3(a)).

**Virtual image** of an object is formed by reflected rays that appear to diverge from the mirror. Such images are always erect and virtual; these cannot be projected on a screen. They are formed behind the mirror (Fig. 20.3(b)).

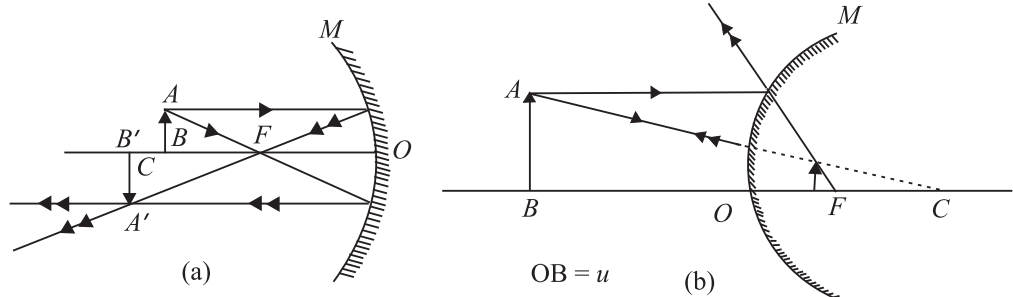

Fig. 20.3 : Image formed by a) concave mirror, and b) convex mirror

20.1.2 Sign Convention

We follow the sign convention based on the cartesian coordinate system. While using this convention, the following points should be kept in mind:

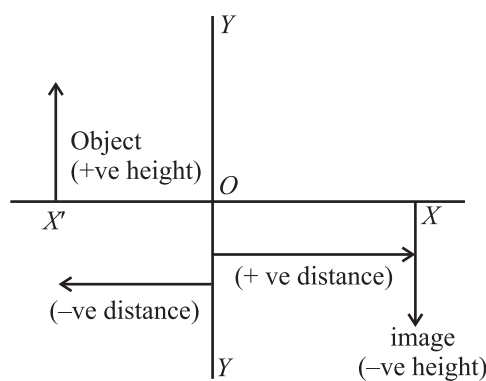

Fig. 20.4 : Sign convention

1. All distances are measured from the pole ( $O$ ) of the mirror. The object is always placed on the left so that the incident ray is always taken as travelling from left to right.
2. All the distances on the left of  $O$  are taken as negative and those on the right of  $O$  as positive.
3. The distances measured above and normal to the principal axis are taken as positive and the downward distances as negative.

The radius of curvature and the focal length of a concave mirror are negative and those for a convex mirror are positive.

## 20.2 DERIVATION OF MIRROR FORMULA

We now look for a relation between the object distance ( $u$ ), the image distance ( $v$ ) and the focal length  $f$  of a spherical mirror. We make use of simple geometry to arrive at a relation, which surprisingly is applicable in all situations. Refer to Fig. 20.5, which shows an object  $AB$  placed in front of a concave mirror. The mirror produces an image  $A'B'$ .

$AX$  and  $AY$  are two rays from the point  $A$  on the object  $AB$ ,  $M$  is the concave mirror while  $XA'$  and  $YA'$  are the reflected rays.

Using sign conventions, we can write

$$\text{object distance, } OB = -u,$$

$$\text{focal length, } OF = -f,$$

$$\text{image distance, } OB' = -v,$$

and radius of curvature  $OC = -2f$

Consider  $\triangle ABF$  and  $\triangle FOY$ . These are similar triangles. We can, therefore, write

$$\frac{AB}{OY} = \frac{FB}{OF} \quad (20.1)$$

Similarly, from similar triangles  $\triangle XOF$  and  $\triangle B'A'F$ , we have

$$\frac{XO}{A'B'} = \frac{OF}{FB'} \quad (20.2)$$

But  $AB = XO$ , as  $AX$  is parallel to the principal axis. Also  $A'B' = OY$ . Since left hand sides of Eqns. (20.1) and (20.2) are equal, we equate their right hand sides. Hence, we have

$$\frac{FB}{OF} = \frac{OF}{FB'} \quad (20.3)$$

Putting the values in terms of  $u$ ,  $v$  and  $f$  in Eqn. (20.3), we can write

$$\frac{-u - (-f)}{-f} = \frac{-f}{-v - (-f)}$$

$$\frac{-u + f}{-f} = \frac{-f}{-v + f}$$

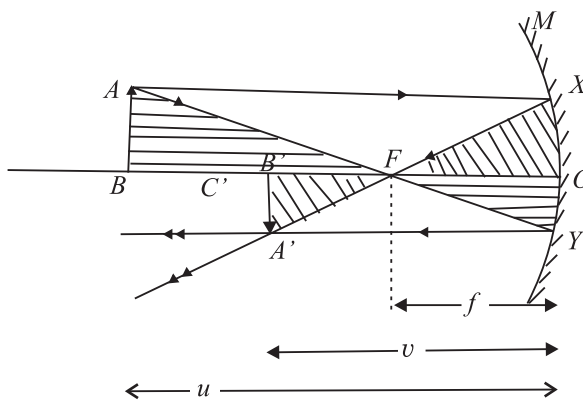

Fig. 20.5 : Image formation by a concave mirror: mirror formula

In optics it is customary to denote object distance by  $u$ . You should not confuse it with velocity.

Notes

## MODULE - 6

### Optics and Optical Instruments

## Reflection and Refraction of Light



### Notes

On cross multiplication, we get

$$uv - uf - vf + f^2 = f^2$$

or  $uv = uf + vf$

Dividing throughout by  $uvf$ , we get the desired relation between the focal length and the object and image distances :

$$\frac{1}{f} = \frac{1}{v} + \frac{1}{u} \quad (20.4)$$

We next introduce another important term **magnification**. This indicates the ratio of the size of image to that of the object :

$$m = \frac{\text{size of the image}}{\text{size of the object}} = \frac{h_2}{h_1}$$

But  $\frac{A'B'}{AB} = \frac{-v}{-u}$

$$\therefore m = -\frac{h_2}{h_1} = \frac{v}{u} \quad (20.5)$$

Since a real image is inverted, we can write

$$m = \frac{A'B'}{AB} = -\frac{v}{u} \quad (20.5b)$$

To solve numerical problems, remember the following steps :

1. For any spherical mirror, use the mirror formula:

$$\frac{1}{f} = \frac{1}{v} + \frac{1}{u}$$

2. Substitute the numerical values of the given quantities with proper signs.
3. Do not give any sign to the quantity to be determined; it will automatically be obtained with the relevant sign.
4. Remember that the linear magnification is negative for a real image and positive for a virtual image.
5. It is always better to draw a figure before starting the (numerical) work.



### INTEXT QUESTIONS 20.2

1. A person standing near a mirror finds his head look smaller and his hips larger. How is this mirror made?
2. Why are the shaving mirrors concave while the rear view mirrors convex? Draw ray diagrams to support your answer.

- As the position of an object in front of a concave mirror of focal length 25cm is varied, the position of the image also changes. Plot the image distance as a function of the object distance letting the latter change from  $-x$  to  $+x$ . When is the image real? Where is it virtual? Draw a rough sketch in each case.
- Give two situations in which a concave mirror can form a magnified image of an object placed in front of it. Illustrate your answer by a ray diagram.
- An object 2.6cm high is 24cm from a concave mirror whose radius of curvature is 16cm. Determine (i) the location of its image, and (ii) size and nature of the image.
- A concave mirror forms a real image four times as tall as the object placed 15cm from it. Find the position of the image and the radius of curvature of the mirror.
- A convex mirror of radius of curvature 20cm forms an image which is half the size of the object. Locate the position of the object and its image.
- A monkey gazes in a polished spherical ball of 10cm radius. If his eye is 20cm from the surface, where will the image of his eye form?

### 20.3 REFRACTION OF LIGHT

When light passes obliquely from a rarer medium (air) to a denser medium (water, glass), there is a change in its direction of propagation. ***This bending of light at the boundary of two dissimilar media is called refraction.***

When a ray of light is refracted at an interface, it obeys the following two laws :

**Law I :** The incident ray, the refracted ray and the normal to the surface at the point of incidence always lie in the same plane.

**Law II :** The ratio of the sine of the angle of incidence to the sine of the angle of refraction is constant for a given pair of media. It is independent of the angle of incidence when light propagates from a rarer to a denser medium. Moreover, for a light of given colour, the ratio depends only on the pair of media.

This law was pronounced by the Dutch scientist Willebrord van Roijen Snell and in his honour is often referred to as ***Snell's law***. According to Snell's law

$$\frac{\sin i}{\sin r} = \mu_{12}$$

where  $\mu_{12}$  is a constant, called the *refractive index* of second medium with respect to the first medium, and determines how much bending would take place at the interface separating the two media. It may also be expressed as the ratio of the



## MODULE - 6

### Optics and Optical Instruments



#### Notes

**Table 20.1 :** Refractive indices of some common materials

Medium	$\mu$
Vacuum/air	1
Water	1.33
Ordinary glass	1.50
Crown glass	1.52
Dense flint glass	1.65
Diamond	2.42

## Reflection and Refraction of Light

velocity of light in the first medium to the velocity of light in the second medium

$$\mu_{12} = \frac{c_1}{c_2}$$

Refractive indices of a few typical substances are given in Table 20.1. Note that these values are with respect to air or vacuum. The medium having larger refractive index is optically denser medium while the one having smaller refractive index is called rarer medium. So water is denser than air but rarer than glass. Similarly, crown glass is denser than ordinary glass but rarer than flint glass.

If we consider refraction from air to a medium like glass, which is optically denser than air [Fig. 20.6 (a)], then  $\angle r$  is less than  $\angle i$ . On the other hand, if the ray passes from water to air,  $\angle r$  is greater than  $\angle i$  [Fig. 20.6(b)]. That is, the refracted ray bends towards the normal on the air–glass interface and bends away from the normal on water–air interface.

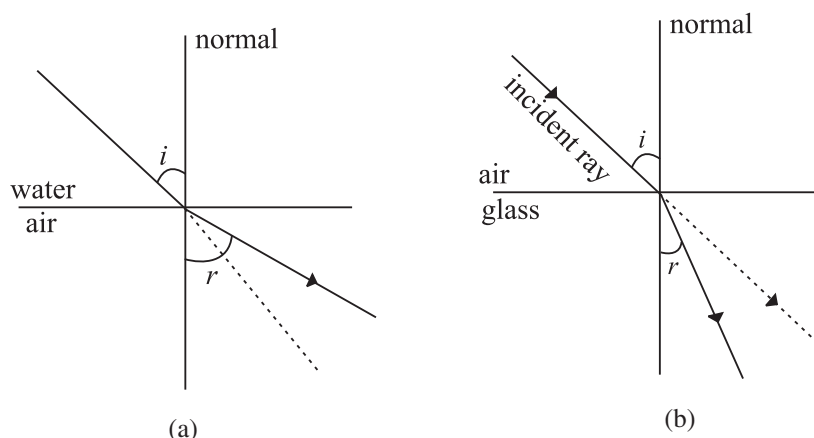

**Fig. 20.6 :** a) Refraction on air–glass interface, and b) refraction on water–air interface

### Willebrord Van Roijen Snell (1580 – 1626)

Willebrord Snell was born in 1580 in Lieden. He began to study mathematics at a very young age. He entered the University of Leiden and initially studied law. But, soon he turned his attention towards mathematics and started teaching at the university by the time he was 20. In 1613, Snell succeeded his father as Professor of Mathematics.



He did some important work in mathematics, including the method of calculating the approximate value of  $\pi$  by polygon. His method of using 96



sided polygon gives the correct value of  $\pi$  up to seven places while the classical method only gave this value upto two correct places. Snell also published some books including his work on comets. However, his biggest contribution to science was his discovery of the laws of refraction. However, he did not publish his work on refraction. It became known only in 1703, seventy seven years after his death, when Huygens published his results in “Dioptrics”.



Notes

### 20.3.1 Reversibility of light

Refer to Fig. 20.6(b) again. It illustrates the principle of reversibility. It appears as if the ray of light is retracing its path. It is not always necessary that the light travels from air to a denser medium. In fact, there can be any combination of transparent media. Suppose, light is incident at a water-glass interface. Then, by applying Snell's law, we have

$$\frac{\sin i_w}{\sin i_g} = \mu_{wg} \quad (20.6)$$

Now, let us consider separate air-glass and air-water interfaces. By Snell's law, we can write

$$\frac{\sin i_a}{\sin i_g} = \mu_{ag}$$

and

$$\frac{\sin i_a}{\sin i_w} = \mu_{aw}$$

On combining these results, we get

$$\mu_{ag} \sin i_g = \mu_{aw} \sin i_w \quad (20.7)$$

This can be rewritten as

$$\frac{\sin i_w}{\sin i_g} = \frac{\mu_{ag}}{\mu_{aw}} \quad (20.8)$$

On comparing Eqns. (20.6) and (20.8), we get

$$\mu_{wg} = \frac{\mu_{ag}}{\mu_{aw}} \quad (20.9)$$

## MODULE - 6

### Optics and Optical Instruments

## Reflection and Refraction of Light



### Notes

This result shows that when light travels from water to glass, the refractive index of glass with respect to water can be expressed in terms of the refractive indices of glass and water with respect to air.

**Example 20.1 :** A ray of light is incident at an angle of  $30^\circ$  at a water-glass interface. Calculate the angle of refraction. Given  $\mu_{ag} = 1.5$ ,  $\mu_{aw} = 1.3$ .

**Solution :** From Eqn. (20.8), we have

$$\frac{\sin i_w}{\sin i_g} = \frac{\mu_{ag}}{\mu_{aw}}$$

$$\frac{\sin 30^\circ}{\sin i_g} = \frac{1.5}{1.3}$$

or 
$$\sin i_g = \left(\frac{1.3}{1.5}\right) \times \frac{1}{2}$$

$$= 0.4446$$

or 
$$i_g = 25^\circ 41'$$

**Example 20.2 :** Calculate the speed of light in water if its refractive index with respect to air is  $4/3$ . Speed of light in vacuum =  $3 \times 10^8 \text{ ms}^{-1}$ .

**Solution :** We know that

$$\mu = \frac{c}{v}$$

or 
$$v = \frac{c}{\mu}$$

$$= \frac{(3 \times 10^8 \text{ ms}^{-1})}{4/3}$$

$$= \frac{3 \times 10^8 \times 3}{4}$$

$$= 2.25 \times 10^8 \text{ ms}^{-1}$$

**Example 20.3 :** The refractive indices of glass and water are 1.52 and 1.33 respectively. Calculate the refractive index of glass with respect to water.

**Solution :** Using Eqn. (20.9), we can write

$$\mu_{wg} = \frac{\mu_{ag}}{\mu_{aw}} = \frac{1.52}{1.33} = 1.14$$



## INTEXT QUESTIONS 20.3

1. What would be the lateral displacement when a light beam is incident normally on a glass slab?
2. Trace the path of light if it is incident on a semicircular glass slab towards its centre when  $\angle i < \angle i_c$  and  $\angle i > \angle i_c$ .
3. How and why does the Earth's atmosphere alter the apparent shape of the Sun and Moon when they are near the horizon?
4. Why do stars twinkle?
5. Why does a vessel filled with water appear to be shallower (less deep) than when without water? Draw a neat ray diagram for it.
6. Calculate the angle of refraction of light incident on water surface at an angle of  $52^\circ$ . Take  $\mu = 4/3$ .



Notes

## 20.4 TOTAL INTERNAL REFLECTION



## ACTIVITY 20.1

Take a stick, cover it with cycle grease and then dip it in water or take a narrow glass bottle, like that used for keeping Homeopathic medicines, and dip it in water. You will observe that the stick or the bottle shine almost like silver. Do you know the reason? This strange effect is due to a special case of refraction. We know that when a ray of light travels from an optically denser to an optically rarer medium, say from glass to air or from water to air, the refracted ray bends away from the normal. This means that the angle of refraction is greater than the angle of incidence. What happens to the refracted ray when the angle of incidence is increased? The bending of refracted ray also increases. However, the maximum value of the angle of refraction can be  $90^\circ$ . **The angle of incidence in the denser medium for which the angle of refraction in rarer medium, air in this case, equals  $90^\circ$  is called the critical angle,  $i_c$ .** The refracted ray then moves along the boundary separating the two media. If the angle of incidence is greater than the critical angle, the incident ray will be reflected back in the same medium, as shown in Fig. 20.7(c). Such a reflection is called **Total Internal Reflection** and the incident ray is said to be totally internally reflected. For total internal reflection to take place, the following two conditions must be satisfied.

- Light must travel from an optically denser to an optically rarer medium.
- The angle of incidence in the denser medium must be greater than the critical angle for the two media.

## MODULE - 6

### Optics and Optical Instruments



#### Notes

## Reflection and Refraction of Light

The glass tube in water in Activity 20.1 appeared silvery as total internal reflection took place from its surface.

An expression for the critical angle in terms of the refractive index may be obtained readily, using Snell's law. For refraction at the glass-air interface, we can write

$$\frac{\sin i}{\sin r} = \mu_{ga}$$

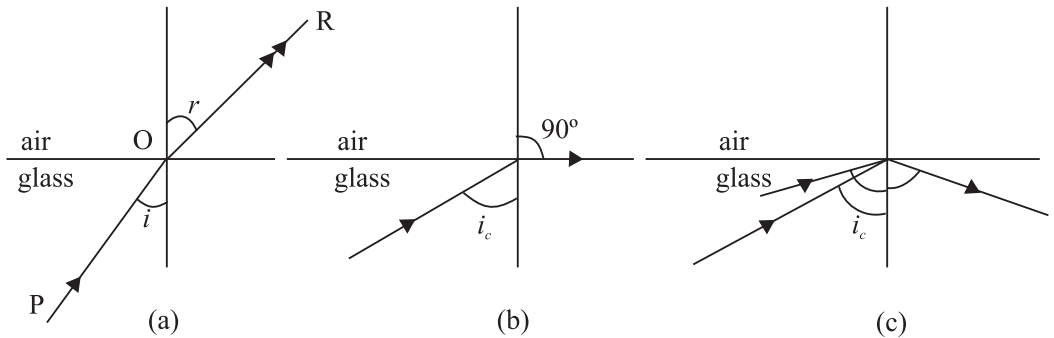

**Fig. 20.7 :** Refraction of light as it travels from glass to air for a)  $i < i_c$ , b)  $i = i_c$  and c)  $i > i_c$

**Table 20.2 :** Critical angles for a few substances

Substance	$\mu$	Critical angle
Water	1.33	48.75°
Crown glass	1.52	41.14°
Diamond	2.42	24.41°
Dense flint glass	1.65	37.31°

Putting  $r = 90^\circ$  for  $i = i_c$ , we have

$$\frac{\sin i_c}{\sin 90^\circ} = \mu_{ga}$$

or

$$\sin i_c = \mu_{ga}$$

Hence

$$\mu_{ag} = \frac{1}{\mu_{ga}} = \frac{1}{\sin i_c}$$

The critical angles for a few substances are given in Table 20.2

**Example 20.4 :** Refractive index of glass is 1.52. Calculate the critical angle for glass air interface.

**Solution :** We know that

$$\mu = 1/\sin i_c$$

$$\sin i_c = 1/\mu = \frac{1}{1.52}$$

$\therefore$

$$i_c = 42^\circ$$

Much of the shine in transparent substances is due to total internal reflection. Can you now explain why diamonds sparkle so much? This is because the critical angle is quite small and most of the light entering the crystal undergoes multiple internal reflections before it finally emerges out of it.

In ordinary reflection, the reflected beam is always weaker than the incident beam, even if the reflecting surface is highly polished. This is due to the fact that some

light is always transmitted or absorbed. But in the case of total internal reflection, cent percent (100%) light is reflected at a transparent boundary.

### 20.4.1 Applications of Refraction and Total Internal Reflection

There are many manifestations of these phenomena in real life situations. We will consider only a few of them.

**(a) Mirage :** Mirage is an optical illusion which is observed in deserts or on tarred roads in hot summer days. This, you might have observed, creates an illusion of water, which actually is not there.

Due to excessive heat, the road gets very hot and the air in contact with it also gets heated up. The densities and the refractive indices of the layers immediately above the road are lower than those of the cooler higher layers. Since there is no abrupt change in medium (see Fig. 20.9), a ray of light from a distant object, such as a tree, bends more and more as it passes through these layers. And when it falls on a layer at an angle greater than the critical angle for the two consecutive layers, total internal reflection occurs. This produces an inverted image of the tree giving an illusion of reflection from a pool of water.

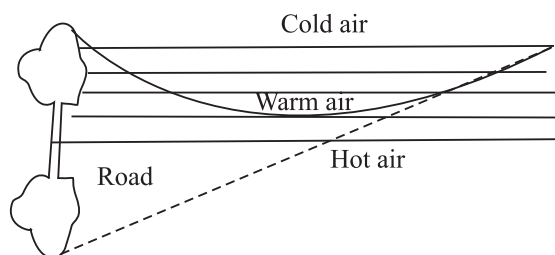

Fig. 20.8 : Formation of mirage

**Totally Reflecting Prisms :** A prism with right angled isosceles triangular base or a totally reflecting prism with angles of  $90^\circ$ ,  $45^\circ$  and  $45^\circ$  is a very useful device for reflecting light.

Refer to Fig. 20.9(a). The symmetry of the prism allows light to be incident on  $O$  at an angle of  $45^\circ$ , which is greater than the critical angle for glass i.e.  $42^\circ$ . As a result, light suffers total internal reflection and is deviated by  $90^\circ$ .

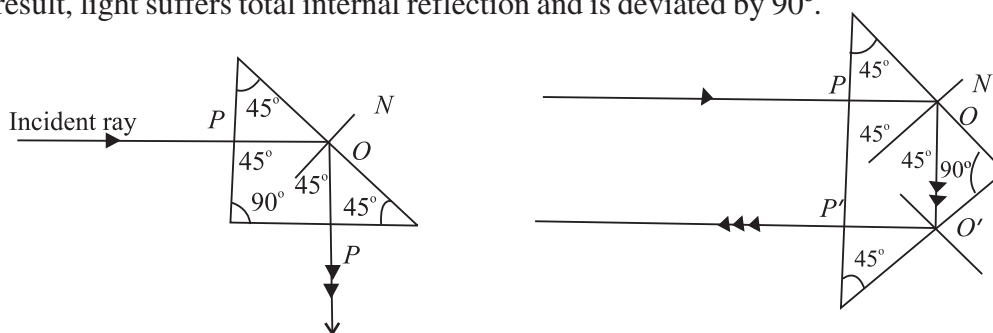

Fig. 20.9 : Totally reflecting prisms



Notes



Notes

Choosing another face for the incident rays, it will be seen (Fig. 20.9(b)) that the ray gets deviated through  $180^\circ$  by two successive total internal reflections taking place at  $O$  and  $O'$ .

### Optical Fibres

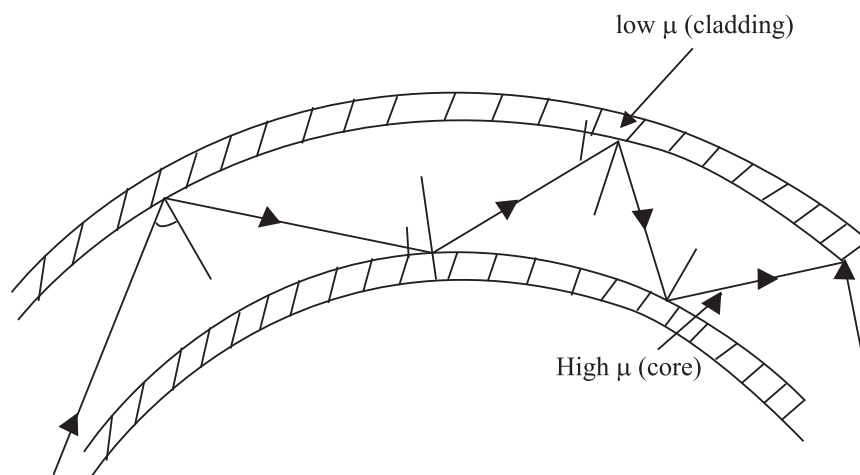

Fig. 20.10 : Multiple reflection in an optical fibre

An optical fibre is a hair-thin structure of glass or quartz. It has an inner core which is covered by a thin layer (called **cladding**) of a material of slightly lower refractive index. For example, the refractive index of the core is about 1.7 and that of the cladding is 1.5. This arrangement ensures total internal reflection. You can easily understand it, if you recall the conditions for total internal reflection.

When light is incident on one end of the fibre at a small angle, it undergoes multiple total internal reflections along the fibre (Fig. 20.10). The light finally emerges with undiminished intensity at the other end. Even if the fibre is bent, this process is not affected. Today optical fibres are used in a big way. A flexible light pipe using optical fibres may be used in the examination of inaccessible parts of the body e.g. laproscopic examination of stomach, urinary bladder etc. Other medical applications of optical fibres are in neurosurgery and study of bronchi. Besides medical applications, optical fibres have brought revolutionary changes in the way we communicate now. Each fibre can carry as many as 10,000 telephone messages without much loss of intensity, to far off places. That is why millions of people across continents can interact simultaneously on a fibre optic network.



### INTEXT QUESTIONS 20.4

1. Why can't total internal reflection take place if the ray is travelling from a rarer to a denser medium?
2. Critical angle for glass is  $42^\circ$ . Would this value change if a piece of glass is immersed in water? Give reason for your answer.

- Show, with the help a ray diagram how, a ray of light may be deviated through  $90^\circ$  using a i) plane mirror, and ii) totally reflecting prism. Why is the intensity of light greater in the second case?
- A liquid in a container is 25cm deep. What is its apparant depth when viewed from above, if the refractive index of the liquid is 1.25? What is the critical angle for the liquid?

## 20.5 REFRACTION AT A SPHERICAL SURFACE

We can study formation of images of objects placed around spherical surfaces such as glass marbles (Kanchas), water drops, glass bottle, etc. For measuring distances from spherical refracting surfaces, we use the same sign convention as applicable for spherical mirrors. Refer to Fig. 20.11.

$SPS'$  is a convex refracting surface separating two media, air and glass.  $C$  is its centre of curvature.  $P$  is a point on  $SPS'$  almost symmetrically placed. You may call it the *pole*.  $CP$  is then the *principal axis*.  $O$  is a point object.  $OA$  is an incident ray and  $AB$  is the refracted ray. Another ray  $OP$  falls on the surface normally and goes undeviated after refraction.  $PC$  and  $AB$  appear to come from  $I$ . Hence  $I$  is the virtual image of  $O$ .

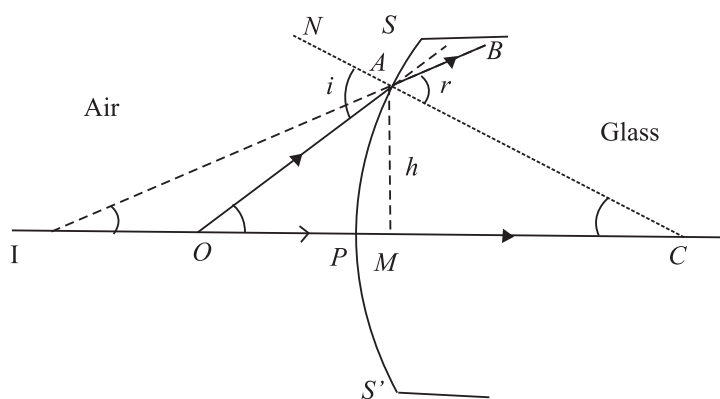

**Fig. 20.11 :** Refraction at a spherical surface

Let  $\angle OAN = i$ , the angle of incidence and  $\angle CAB = r$ , the angle of refraction. Using the proper sign convention, we can write

$$PO = -u ; PI = -v ; PC = +R$$

Let  $\alpha$ ,  $\beta$ , and  $\gamma$  be the angles subtended by  $OA$ ,  $IA$  and  $CA$ , respectively with the principal axis and  $h$  the height of the normal dropped from  $A$  on the principal axis. In  $\triangle OCA$  and  $\triangle ICA$ , we have

$$i = \alpha + \gamma \quad (i \text{ is exterior angle}) \quad (20.10)$$

and 
$$r = \beta + \gamma \quad (r \text{ is exterior angle}) \quad (20.11)$$





Notes

From Snell's law, we recall that

$$\frac{\sin i}{\sin r} = \mu$$

where  $\mu$  is the refractive index of the glass surface with respect to air. For a surface of small aperture,  $P$  will be close to  $A$  and so  $i$  and  $r$  will be very small ( $\sin i \simeq i$ ,  $\sin r \simeq r$ ). The above equation, therefore, gives

$$i = \mu r \quad (20.12)$$

Substituting the values of  $i$  and  $r$  in Eqn. (20.12) from Eqns. (20.10) and (20.11) respectively, we get

$$\alpha + \gamma = \mu (\beta + \gamma)$$

or 
$$\alpha - \mu\beta = \gamma (\mu - 1) \quad (20.13)$$

As  $\alpha$ ,  $\beta$  and  $\gamma$  are very small, we can take  $\tan \alpha \simeq \alpha$ , and  $\tan \beta \simeq \beta$ , and  $\tan \gamma \simeq \gamma$ . Now referring to  $\Delta OAM$  in Fig. 20.11, we can write

$$\alpha \approx \tan \alpha = \frac{AM}{MO} = \frac{AP}{PO} = \frac{h}{-u} \quad (\text{if } M \text{ is very near to } P)$$

$$\beta \approx \tan \beta = \frac{AM}{MI} = \frac{AM}{PI} = \frac{h}{-v}$$

and 
$$\gamma \simeq \tan \gamma = \frac{AM}{MC} = \frac{AM}{PC} = \frac{h}{R}$$

Substituting for  $\alpha$ ,  $\beta$  and  $\gamma$  in Eqn. (20.13), we get

$$\frac{h}{-u} - \frac{\mu h}{v} = (\mu - 1) \frac{h}{R}$$

or 
$$\frac{\mu}{v} - \frac{1}{u} = \frac{\mu - 1}{R} \quad (20.14)$$

This important relationship correlates the object and image distances to the refractive index  $\mu$  and the radius of curvature of the refracting surface.

### 20.5.1 Reflection through lenses

A lens is a thin piece of transparent material (usually glass) having two surfaces, one or both of which are curved (mostly spherical). You have read in your earlier classes that lenses are mainly of two types, namely, convex lens and concave lens. Each of them is sub-divided into three types as shown in Fig. 20.12. Thus, you can have plano-convex and plano-concave lenses too.



### Basic Nomenclature

**Thin lens :** If the thickness of a lens is negligible in comparison to the radii of curvature of its curved surfaces, the lens is referred to as a thin lens. We will deal with thin lenses only.

**Principal axis** is the line joining the centres of curvature of two surfaces of the lens.

**Optical centre** is the point at the center of the lens situated on the principal axis. The rays passing through the optical centre do not deviate.

**Principal focus** is the point at which rays parallel and close to the principal axis converge to or appear to diverge. It is denoted by  $F$  (Fig. 20.13) Rays of light can pass through a lens in either direction. So every lens has two principal focii, one on its either side.

**Focal length** is the distance between the optical centre and the principal focus. In Fig. 20.13,  $OF$  is focal length ( $f$ ). As per the sign convention,  $OF$  is positive for a convex lens and negative for a concave lens.

**Focal plane** is the plane passing through the focus of a lens perpendicular to its principal axis.

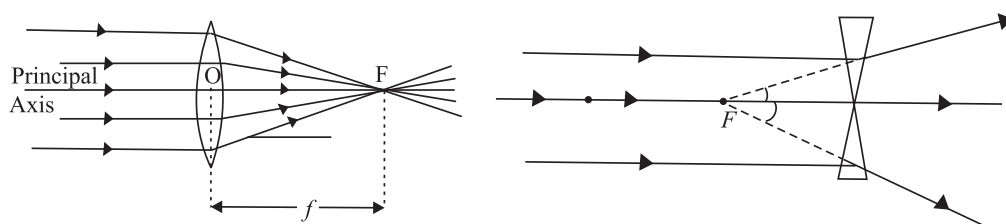
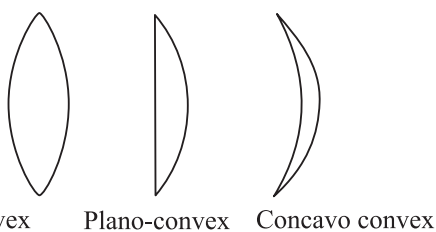

Fig. 20.13 : Foci of a) convex, and b) concave lenses

### 20.5.2 Lens Maker's Formula and Magnification

You can now guess that the focal length must be related to the radius of curvature and the refractive index of the material of the lens. Suppose that a thin convex lens  $L$  is held on an optical bench (Fig. 20.14). Let the refractive index of the material of the lens with respect to air be  $\mu$  and the radii of curvatures of its two surfaces be  $R_1$  and  $R_2$ , respectively. Let a point object be situated on the principal



(a) Bi-convex      Plano-convex      Concavo convex

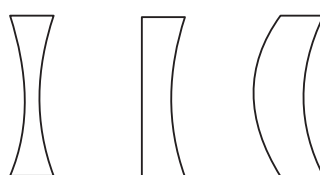

(b) Biconcave      Plano-concave      Convex concavo

Fig. 20.12 : Types of lenses



Notes

## MODULE - 6

### Optics and Optical Instruments

### Reflection and Refraction of Light



#### Notes

Since the lens used is actually thin, points  $A$  and  $B$  may be considered very close to point  $a$  and hence  $C_1A$  is taken equal to  $C_1Q$  and  $C_2B$  as  $C_2Q$ .

axis at  $P$ .  $C_1$  and  $C_2$  are the centres of curvature of the curved surfaces 1 and 2, respectively.

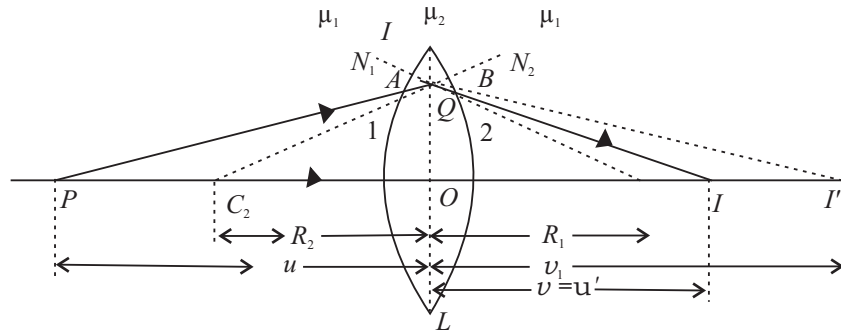

**Fig. 20.14 :** Point image of a point object for by a thin double convex lens

A ray from  $P$  strikes surface 1 at  $A$ .  $C_1N_1$  is normal to surface 1 at the point  $A$ . The ray  $PA$  travels from the rarer medium (air) to the denser medium (glass), and bends towards the normal to proceed in the direction  $AB$ . The ray  $AB$  would meet the principal axis  $C_2C_1$  at the point  $I'$  in the absence of the surface 2. Similarly, another ray from  $P$  passing through the optical centre  $O$  passes through the Point  $I'$ .  $I'$  is thus the virtual image of the object  $P$ .

Then object distance  $OP = u$  and image distance  $OI' = v_1$  (say). Using Eqn. (20.14) we can write

$$\frac{\mu}{v_1} - \frac{1}{u} = \frac{\mu - 1}{R_1} \quad (20.15)$$

Due to the presence of surface 2, the ray  $AB$  strikes it at  $B$ .  $C_2N_2$  is the normal to it at point  $B$ . As the ray  $AB$  is travelling from a denser medium (glass) to a rarer medium (air), it bends away from the normal  $C_2N_2$  and proceeds in the direction  $BI$  and meets another ray from  $P$  at  $I$ . Thus  $I$  is image of the object  $P$  formed by the lens. It means that image distance  $OI = v$ .

Considering point object  $O$ , its virtual image is  $I'$  (due to surface 1) and the final image is  $I$ .  $I'$  is the virtual object for surface 2 and  $I$  is the final image. Then for the virtual object  $I'$  and the final image  $I$ , we have, object distance  $OI' = u' = v_1$  and image distance  $OI = v$ .

On applying Eqn. (20.12) and considering that the ray  $AB$  is passing from *glass to air*, we have

$$\frac{(1/\mu)}{v} + \frac{1}{v_1} = \frac{(1/\mu) - 1}{R_2}$$

or,

$$\frac{1}{\mu v} - \frac{1}{v_1} = \frac{1 - \mu}{\mu R_2}$$

Multiplying both sides by  $\mu$ , we get

$$\frac{1}{v} - \frac{\mu}{v_1} = \frac{\mu - 1}{R_2} \quad (20.16)$$

Adding Eqns. (20.15) and (20.16), we have

$$\frac{1}{v} - \frac{1}{u} = (\mu - 1) \left( \frac{1}{R_1} - \frac{1}{R_2} \right) \quad (20.17)$$

If  $u = \infty$ , that is the object is at infinity, the incoming rays are parallel and after refraction will converge at the focus ( $v = f$ ). Then Eqn. (20.17) reduces to

$$\frac{1}{f} = (\mu - 1) \left( \frac{1}{R_1} - \frac{1}{R_2} \right) \quad (20.18)$$

This is called lens maker's formula.

From Eqns. (20.17) and (20.18), we can conclude that

- The focal length of a lens depends on the radii of curvature of spherical surfaces. Focal length of a lens of larger radii of curvature will be more.
- Focal length of a lens is smaller if the refractive index of its material is high.

In case a lens is dipped in water or any other transparent medium, the value of  $\mu$  changes and you can actually work out that focal length will increase. However, if the density of the medium is more than that of the material of the lens, say carbon disulphide, the rays may even diverge.

### 20.5.3 Newton's Formula

Fig. 20.5.3 shows the image of object  $AB$  formed at  $A'B'$  by a convex lens  $F_1$  and  $F_2$  are the first and second principal foci respectively.

Let us measure the distances of the object and image from the first focus and second focus respectively. Let  $x_1$  be the distance of object from the first focus and  $x_2$  be the distance of image from the second focus and  $f_1$  and  $f_2$  the first and second focal lengths, respectively as shown in Fig. 20.5.3.

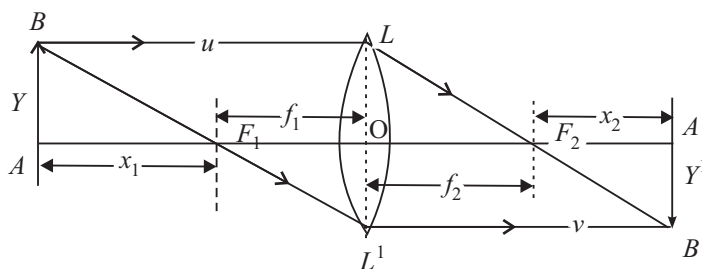

Fig. 20.5.3



Notes



Notes

Now, in similar  $\Delta$ s,  $ABF_1$  and  $OL'F_1$

$$\frac{-y'}{y} = \frac{-f_1}{-x_1}$$

Also from similar  $\Delta$ s,  $OLF_2$  and  $A'B'F_2$

$$\frac{-y'}{y} = \frac{x_2}{f_2}$$

Comparing these two equations we get

$$x_1x_2 = f_1f_2$$

for  $f_1 \equiv f_2 \approx f$  (say), then  $x_1x_2 = +f^2$

or  $f = \sqrt{x_1x_2}$

This relation is called Newton's formula and can be conveniently used to measure the focal length.

**20.5.4 Displacement Method to find the Position of Images (Conjugates points)**

In the figure 20.5.4,  $A'B'$  is the image of the object  $AB$  as formed by a lens  $L$ .  $OA = u$  and  $OA' = v$ .

The principle of reversibility of light rays tells us that if we move the lens towards the right such that  $AO = v$ , then again the image will be formed at the same place.

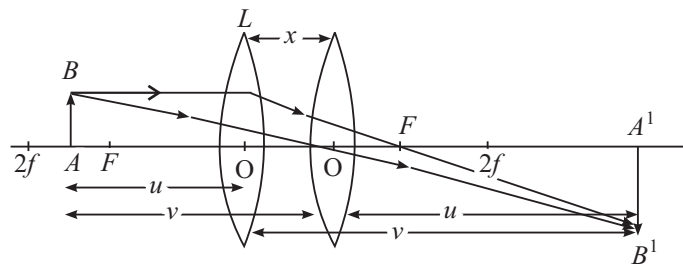

Fig. 20.5.4

Thus  $AA' = D = u + v$  ... (i)

and the separation between the two positions of the lens:

$OO' = x = (v - u)$  ... (ii)



Notes

Adding (i) and (ii) we get

$$v = \frac{x+D}{2}$$

and, subtracting (ii) from (i) we get

$$u = \frac{D-x}{2}$$

Substituting these values in the lens formula, we get.

$$\frac{1}{f} = \frac{1}{v} - \frac{1}{(-u)}$$

$$\frac{1}{f} = \frac{2}{x+D} + \frac{2}{D-x} = \frac{2}{D+x} + \frac{2}{D-x}$$

$$\frac{1}{f} = \frac{2(D-x+D+x)}{D^2-x^2}$$

$$\frac{1}{f} = \frac{4D}{D^2-x^2}$$

or

$$f = \frac{D^2-x^2}{4D}$$

Thus, keeping the positions of the object and screen fixed we can obtain equally clear, bright and sharp images of the object on the screen corresponding to the two positions of the lens. This again is a very convenient way of finding  $f$  of a lens.

## 20.6 FORMATION OF IMAGES BY LENSES

The following properties of the rays are used in the formation of images by lenses:

- A ray of light through the optical centre of the lens passes undeviated.
- A parallel ray, after refraction, passes through the principal focus.
- A ray of light through  $F$  or  $F'$  is rendered parallel to the principal axis after refraction.

Any two of these rays can be chosen for drawing ray diagrams.

The lens formula  $\frac{1}{f} = \frac{1}{v} - \frac{1}{u}$  suggests the dependence of the image distance ( $v$ ) on the object distance ( $u$ ) and the focal length ( $f$ ) of the lens.

## MODULE - 6

### Optics and Optical Instruments



#### Notes

## Reflection and Refraction of Light

*The magnification of a lens is defined as the ratio of the height of the image formed by the lens to the height of the object and is denoted by  $m$  :*

$$m = \frac{I}{O} = \frac{v}{u}$$

where  $I$  is height of the image and  $O$  the height of the object.

**Example 20.5 :** The radii of curvature of a double convex lens are 15cm and 30cm, respectively. Calculate its focal length. Also, calculate the focal length when it is immersed in a liquid of refractive index 1.65. Take  $\mu$  of glass = 1.5.

**Solution :** From Eqn. (20.18) we recall that

$$\frac{1}{f} = (\mu - 1) \left( \frac{1}{R_1} - \frac{1}{R_2} \right)$$

Here  $R_1 = +15\text{cm}$ , and  $R_2 = -30\text{cm}$ . On substituting the given data, we get

$$\frac{1}{f} = (1.5 - 1) \left( \frac{1}{15} - \frac{1}{-30} \right)$$

$$\Rightarrow f = 20 \text{ cm}$$

When the lens is immersed in a liquid,  $\mu$  will be replaced by  $\mu_{lg}$  :

$$\begin{aligned} \mu_{lg} &= \frac{\mu_{ag}}{\mu_{al}} \\ &= \frac{1.5}{1.65} = \frac{10}{11} \end{aligned}$$

Therefore

$$\begin{aligned} \frac{1}{f_l} &= (\mu_{lg} - 1) \left( \frac{1}{R_1} - \frac{1}{R_2} \right) \\ &= \left( \frac{10}{11} - 1 \right) \left( \frac{1}{15} - \frac{1}{-30} \right) \\ &= -\frac{1}{110} \end{aligned}$$

$$\therefore f = -110\text{cm}$$

As  $f$  is negative, the lens indeed behaves like a concave lens.

## 20.7 POWER OF A LENS

A practical application of lenses is in the correction of the defects of vision. You may be using spectacles or seen other learners, parents and persons using

spectacles. However, when asked about the power of their lens, they simply quote a positive or negative number. What does this number signify? This number is the power of a lens in dioptre. The power of a lens is defined as the reciprocal of its focal length in metre:

$$P = \frac{1}{f}$$

The SI unit of power of a lens is  $\text{m}^{-1}$ . Dioptre is only a commercial unit generally used by opticians. The power of a convex lens is positive and that of a concave lens is negative. Note that greater power implies smaller focal length. Using lens maker's formula, we can relate power of a lens to its radii of curvature:

$$\frac{1}{f} = (\mu - 1) \left( \frac{1}{R_1} - \frac{1}{R_2} \right)$$

or

$$P = (\mu - 1) \left( \frac{1}{R_1} - \frac{1}{R_2} \right)$$

**Example 20.6 :** Calculate the radius of curvature of a biconvex lens with both surfaces of equal radii, to be made from glass ( $\mu = 1.54$ ), in order to get a power of +2.75 dioptre.

**Solution :**

$$P = (\mu - 1) \left( \frac{1}{R_1} - \frac{1}{R_2} \right)$$

$$P = +2.75 \text{ dioptre}$$

$$\mu = 1.54$$

$$R_1 = R$$

and

$$R_2 = -R$$

Substituting the given values in lens maker's formula, we get

$$2.75 = (0.54) \left( \frac{2}{R} \right)$$

$$R = \frac{0.54 \times 2}{2.75}$$

$$= 0.39 \text{ m}$$

$$= 39 \text{ cm}$$

## 20.8 COMBINATION OF LENSES

Refer to Fig. 20.15. Two thin convex lenses  $A$  and  $B$  having focal lengths  $f_1$  and  $f_2$ , respectively have been kept in contact with each other.  $O$  is a point object placed on the common principal axis of the lenses.



Notes

## MODULE - 6

### Optics and Optical Instruments



Notes

## Reflection and Refraction of Light

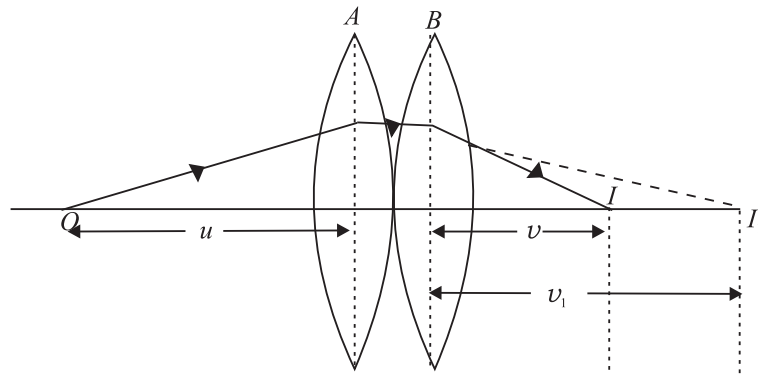

Fig. 20.15 : Two thin convex lenses in contact

Note that lens  $A$  forms the image of object  $O$  at  $I_1$ . This image serves as the *virtual* object for lens  $B$  and the final image is thus formed at  $I$ . If  $v$  be the object distance and  $v_1$  the image distance for the lens  $A$ , then using the lens formula, we can write

$$\frac{1}{v_1} - \frac{1}{u} = \frac{1}{f_1} \quad (20.19)$$

If  $v$  is the final image distance for the lens  $B$ , we have

$$\frac{1}{v} - \frac{1}{v_1} = \frac{1}{f_2} \quad (20.20)$$

Note that in writing the above expression, we have taken  $v_1$  as the object distance for the thin lens  $B$ .

Adding Eqns. (20.19) and (20.20), we get

$$\frac{1}{v} - \frac{1}{u} = \frac{1}{f_1} + \frac{1}{f_2} \quad (20.21)$$

If the combination of lenses is replaced by a single lens of focal length  $F$  such that it forms the image of  $O$  at the same position  $I$ , then this lens is said to be equivalent to both the lenses. It is also called the *equivalent lens* for the combination. For the equivalent lens, we can write

$$\frac{1}{v} - \frac{1}{u} = \frac{1}{F} \quad (20.22)$$

where

$$\frac{1}{F} = \frac{1}{f_1} + \frac{1}{f_2} \quad (20.23)$$



If  $P$  is power of the equivalent lens and  $P_1$  and  $P_2$  are respectively the powers of individual lenses, then

$$P = P_1 + P_2 \quad (20.24)$$

Note that Eqns.(20.23) and (20.24) derived by assuming two thin convex lenses in contact also hold good for any combination of two thin lenses in contact (the two lenses may both be convex, or concave or one may be concave and the other convex).

**Example 20.7 :** Two thin convex lenses of focal lengths 20cm and 40cm are in contact with each other. Calculate the focal length and the power of the equivalent lens.

**Solution :** The formula for the focal length of the combination  $\frac{1}{F} = \frac{1}{f_1} + \frac{1}{f_2}$  gives

$$\begin{aligned} \frac{1}{F} &= \frac{1}{20} + \frac{1}{40} \\ &= \frac{3}{40} \end{aligned}$$

or 
$$F = \frac{40}{3} = 13.3\text{cm} = 0.133\text{m}$$

Power of the equivalent lens is

$$P = \frac{1}{F} = \frac{1}{0.133} = +7.5 \text{ dioptre.}$$



### INTEXT QUESTIONS 20.5

1. On what factors does the focal length of a lens depend?
2. A lens, whose radii of curvature are different, is used to form the image of an object placed on its axis. If the face of the lens facing the object is reversed, will the position of the image change?
3. The refractive index of the material of an equi-double convex lens is 1.5. Prove that the focal length is equal to the radius of curvature.
4. What type of a lens is formed by an air bubble inside water?
5. A lens when immersed in a transparent liquid becomes invisible. Under what condition does this happen?
6. Calculate the focal length and the power of a lens if the radii of curvature of its two surfaces are +20cm and -25cm ( $\mu = 1.5$ ).



Notes



Notes

7. Is it possible for two lenses in contact to produce zero power?
8. A convex lens of focal length 40cm is kept in contact with a concave lens of focal length 20cm. Calculate the focal length and the power of the combination.

Defects in image formation

Lenses and mirrors are widely used in our daily life. It has been observed that they do not produce a point image of a point object. This can be seen by holding a lens against the Sun and observing its image on a paper. You will note that it is not exactly circular. Mirrors too do not produce a perfect image. The defects in the image formation are known as **aberrations**. The aberrations depend on (i) the quality of lens or mirror and (ii) the type of light used.

Two major aberrations observed in lenses and mirrors, are (a) **spherical aberration** and (b) **chromatic aberration**. These aberration produce serious defects in the images formed by the cameras, telescopes and microscopes etc.

Spherical Aberration

This is a monochromatic defect in image formation which arises due to the sphericity and aperture of the refracting or reflecting surfaces. The paraxial rays and the marginal rays form images at different points  $I_p$  and  $I_m$  respectively (Fig. 20.16)

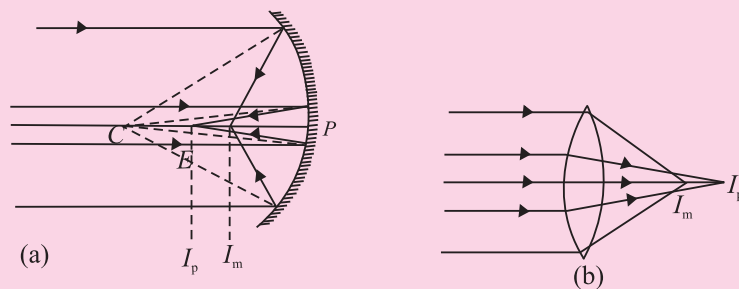

Fig. 20.16 :Spherical aberration in a) spherical mirror, and b) lens.  $I_p$  is image formed by the paraxial rays and  $I_m$  that formed by the marginal rays.

The **spherical aberration** in both mirrors and lenses can be reduced by allowing only the paraxial rays to be incident on the surface. It is done by using stops. Alternatively, the paraxial rays may be cut-off by covering the central portion, thus allowing only the marginal or parapheral rays to form the image. However, the use of stops reduces the brightness of the image.

A much appreciated method is the use of elliptical or parabolic mirrors.

The other methods to minimize spherical aberration in lenses are : use of plano convex lenses or using a suitable combination of a convex and a concave lens.

### Chromatic Aberration in Lenses

A convex lens may be taken as equivalent to two small-angled prisms placed base to base and the concave lens as equivalent to such prisms placed vertex to vertex. Thus, a polychromatic beam incident on a lens will get dispersed. The parallel beam will be focused at different coloured foci. This defect of the image formed by spherical lenses is called **chromatic aberration**. It occurs due to the dispersion of a polychromatic incident beam (Fig. 20.17). Obviously the red colour is focused farther from the lens while the blue colour is focused nearer the lens (in a concave lens the focusing of the red and blue colours takes place in the same manner but on the opposite side of it).

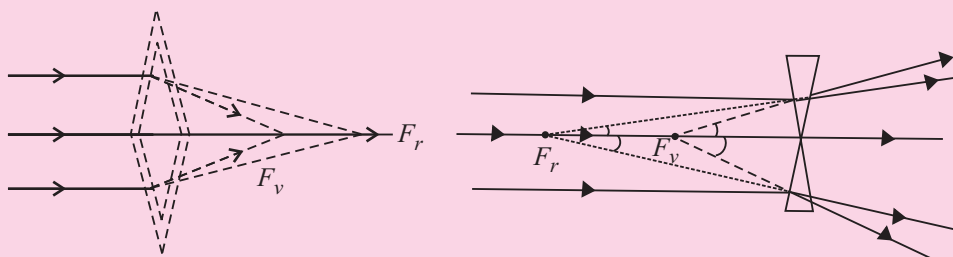

Fig. 20.17: Chromatic aberration

To remove this defect we combine a convergent lens of suitable material and focal length when combined with a divergent lens of suitable focal length and material. Such a lens combination is called an **achromatic doublet**. The focal length of the concave lens can be found from the necessary condition for achromatism given by

$$\frac{\omega_1}{f_1} + \frac{\omega_2}{f_2} = 0$$



### WHAT YOU HAVE LEARNT

- Real image is formed when reflected rays actually intersect after reflection. It can be projected on a screen.
- The focal length is half of the radius of curvature.

$$f = \frac{R}{2}$$



Notes

## MODULE - 6

### Optics and Optical Instruments



#### Notes

## Reflection and Refraction of Light

The object and image distances are related to magnification as

$$m = \frac{v}{u}$$

- Refraction of light results in change in the speed of light when it travels from one medium to another. This causes the rays of light to bend towards or away from the normal.

- The refractive index  $\mu$  determines the extent of bending of light at the interface of two media.

- Snell's law is mathematically expressed as

$$\frac{\sin i}{\sin r} = \mu_{12}$$

where  $i$  is the angle of incidence in media 1 and  $r$  is the angle of refraction in media 2.

- Total internal reflection is a special case of refraction wherein light travelling from a denser to a rarer media is incident at an angle greater than the critical angle:

$$\mu = \frac{1}{\sin i_c}$$

- Any transparent media bounded by two spherical surfaces or one spherical and one plane surface forms a lens.

- Images by lenses depend on the focal length and the distance of the object from it.

- Convex lenses are converging while concave lenses are diverging.

- $$\frac{1}{f} = (\mu - 1) \left( \frac{1}{R_1} - \frac{1}{R_2} \right)$$

$$m = \frac{v}{u}$$

and 
$$\frac{1}{f} = \frac{1}{v} - \frac{1}{u}$$

are simple relationships between the focal length ( $f$ ), the refractive index, the radii of curvatures ( $R_1, R_2$ ), the object distance ( $u$ ) and the image distance ( $v$ ).

- Newton's formula can be used to measure the focal length of a lens.

- Displacement method is a very convenient way of finding focal length of a lens.

- Power of a lens indicates how diverging or converging it is:

$$P = \frac{1}{f}$$

Power is expressed in dioptre. (or  $\text{m}^{-1}$  in SI units)

- The focal length  $F$  of an equivalent lens when two their lenses of focal lengths  $f_1$  and  $f_2$  one kept in contact is given by

$$\frac{1}{F} = \frac{1}{f_1} + \frac{1}{f_2}$$



### TERMINAL EXERCISES

1. List the uses of concave and convex mirrors.
2. What is the nature and position of image formed when the object is at (i) infinity (ii)  $2f$  (iii)  $f$  in case of concave mirror and convex mirror.
3. List the factors on which lateral displacement of an incident ray depends as it suffers refraction through a parallel-sided glass slab? Why is the lateral displacement larger if angle of incidence is greater. Show this with the help of a ray diagram.
4. State conditions for total internal reflection of light to take place.
5. How is  $+1.5$  dioptre different from  $-1.5$  dioptre? Define dioptre.
6. Why does the intensity of light become less due to refraction?
7. A lamp is  $4\text{m}$  from a wall. Calculate the focal length of a concave mirror which forms a five times magnified image of the lamp on the wall. How far from the wall must the mirror be placed?
8. A dentist's concave mirror has a radius of curvature of  $30\text{cm}$ . How far must it be placed from a cavity in order to give a virtual image magnified five times?
9. A needle placed  $45\text{cm}$  from a lens forms an image on a screen placed  $90\text{cm}$  on the other side of the lens. Identify the type of the lens and determine its focal length. What is the size of the image, if the size of the needle is  $5.0\text{cm}$ ?
10. An object of size  $3.0\text{cm}$  is placed  $14\text{cm}$  in front of a concave lens of focal length  $21\text{cm}$ . Describe the nature of the image by the lens. What happens if the object is moved farther from the lens?
11. An object is placed at a distance of  $100\text{cm}$  from a double convex lens which forms a real image at a distance of  $20\text{cm}$ . The radii of curvature of the surfaces



Notes

## MODULE - 6

### Optics and Optical Instruments



#### Notes

## Reflection and Refraction of Light

- of a lens are 25cm and 12.5 cm respectively. Calculate the refractive index of the material of the lens.
- A ray of light is travelling from diamond to glass. Calculate the value of the critical angle for the ray, if the refractive index of glass is 1.51 and that of diamond 2.47.
  - A small object is placed at a distance of 15cm from two coaxial thin convex lenses in contact. If the focal length of each lens is 20cm. Calculate the focal length and the power of the combination and the distance between the object and its image.
  - While finding the focal length of a convex lens, an object was kept at a distance of 65.0 cm from the screen. Two positions of the lens for which clear image of the object was formed on the screen were obtained. The distance between these two positions was found to be 15 cm. Calculate the focal length of the given lens.



## ANSWERS TO INTEXT QUESTIONS

### 20.1

- plane mirror (its radius of curvature is infinitely large).
  - No. The focal length of a spherical mirror is half of its radius of curvature ( $f \approx R/2$ ) and has nothing to do with the medium in which it is immersed.
  - Virtual
  - This is because the rays parallel to the principal axis converge at the focal point  $F$ ; and the rays starting from  $F$ , after reflection from the mirror, become parallel to the principal axis. Thus,  $F$  serves both as the first and the second focal point.
- Focal lengths : 2.5cm, 3.5cm, 5cm.

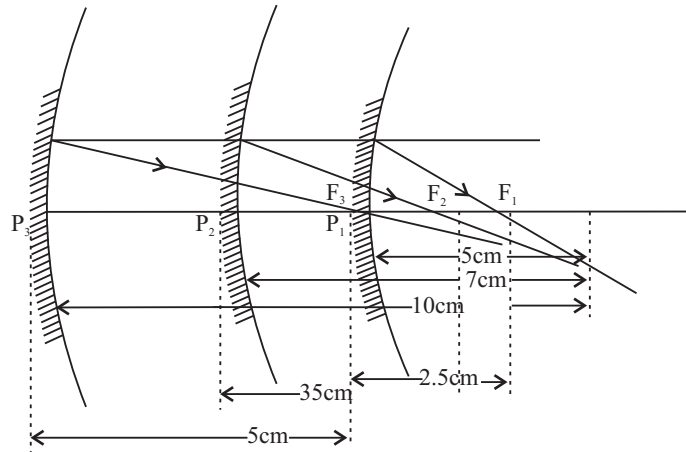



Notes

- $f = -15\text{cm}; f = +15\text{cm}$ .
- The dish antennas are curved so that the incident parallel rays can be focussed on the receiver.

20.2

- The upper part of the mirror must be convex and its lower part concave.
- Objects placed close to a concave mirror give an enlarged image. Convex mirrors give a diminished erect image and have a larger field of view.

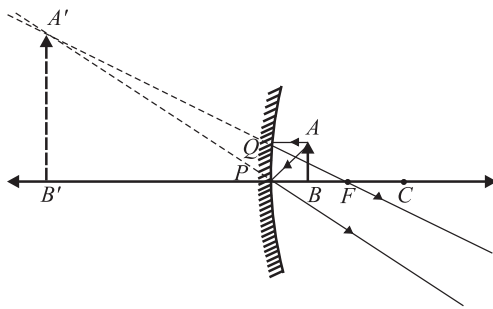

(a) Image formed by concave mirror

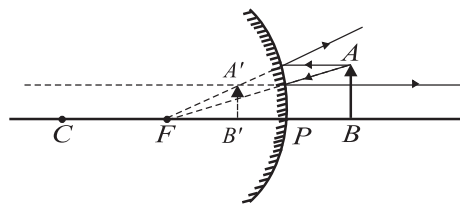

(b) Image formed by convex mirror

- for  $|u| > f$ , we get real image;  $u = -2f$  is a special case when an object kept as the centre of curvature of the mirror forms a real image at this point itself ( $v = -2f$ ). For  $u < f$ , we get virtual image.

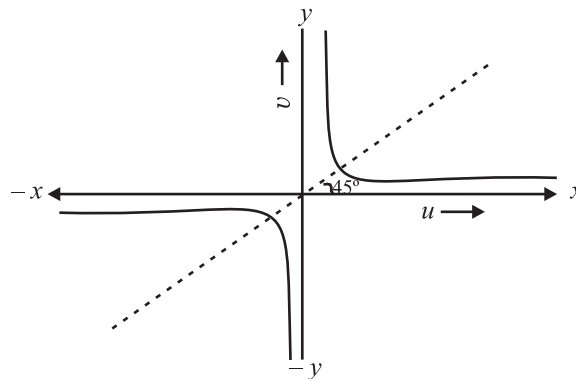

- When (i)  $u < f$ , and (ii)  $f < u < 2f$ .

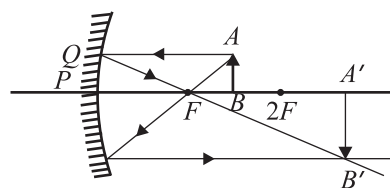
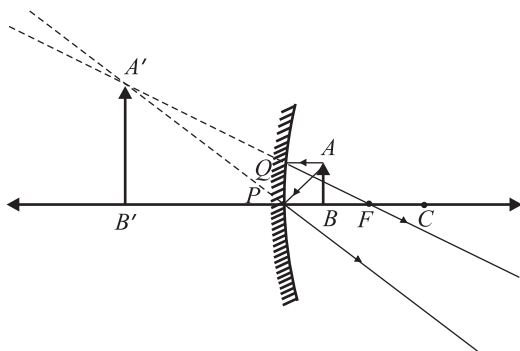

## MODULE - 6

### Optics and Optical Instruments

## Reflection and Refraction of Light



### Notes

- (i) 12cm in front of mirror, real and inverted, (ii) 0.8cm
- $v = -60\text{cm}$ ,  $R = -24\text{cm}$     7.  $u = -10\text{cm}$ ,  $v = +5\text{cm}$
- $v = 4\text{cm}$

### 20.3

- No lateral displacement.

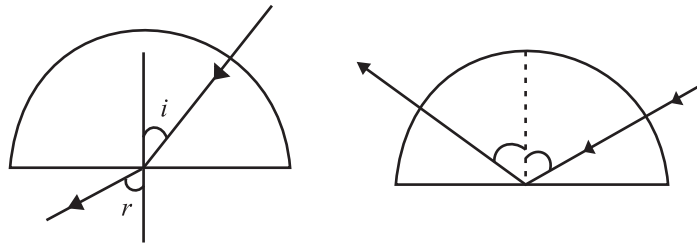

- $\angle r > \angle i$  when  $\angle i < \angle i_c$     Total internal reflection where  $\angle i > \angle i_c$
- The density of air and hence its refractive index decrease as we go higher in altitude. As a result, the light rays from the Sun, when it is below the horizon, pass from the rarer to the denser medium and bend towards the normal, till they are received by the eye of the observer. This causes the shape to appear elongated.
- Due to the change in density of the different layers of air in the atmosphere,  $\mu$  changes continuously. Therefore, the refractive index of air varies at different levels of atmosphere. This along with air currents causes twinkling of stars.
- Due to refraction point  $P$  appears at  $P'$ .

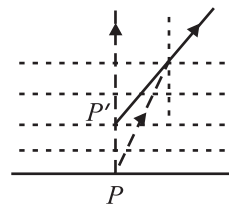

- $36.2^\circ$

### 20.4

- Total internal reflection cannot take place if the ray travels from a rarer to a denser medium as the angle of refraction will always be less than the angle of incidence.
- Yes the critical angle will change as

$$\mu_{\text{ag}} = \frac{1}{\sin i_c} \qquad \mu_{\text{og}} = \frac{\mu_{\text{ag}}}{\mu_{\text{aw}}}$$



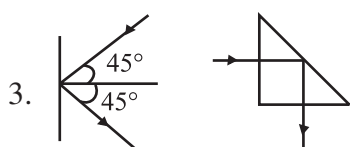

The intensity in the second case is more due to total internal reflection.

4. 20cm,  $i_c = \sin^{-1} 0.8$

### 20.5

2. No. Changing the position of  $R_1$  and  $R_2$  in the lens maker's formula does not affect the value of  $f$ . So the image will be formed in the same position.
3. Substitute  $R_1 = R$ ;  $R_2 = -R$  and  $\mu = 1.5$  in the lens maker's formula. You will get  $f = R$ .
4. Concave lens. But it is shaped like a convex lens.
5. This happens when the refractive index of the material of the lens is the same as that of the liquid.
6.  $f = 22.2$  cm and  $P = 4.5$  dioptre
7. Yes, by placing a convex and a concave lens of equal focal length in contact.
8.  $-40$ cm,  $-2.5$  dioptre

### Answers to Problems in Terminal Exercise

7.  $f = -0.83$ , 5m.                      8. 12cm
9.  $f = 30$ cm, size of image = 10cm, converging lens
10. The image is erect, virtual and diminished in size, and located at 8.4cm from the lens on the same side as the object. As the object is moved away from the lens, the virtual image moves towards the focus of the lens but never beyond and progressively diminishes in size.
11.  $\mu = 1.5$                                   12.  $37.7^\circ$
13. 10cm, 10 dioptre, 45 cm.
14.  $f = 15.38$  cm

