

## Senior Secondary Course

# 373 – Physical Education and Yog

---

## Book-2



373en



### **NATIONAL INSTITUTE OF OPEN SCHOOLING**

(An autonomous organisation under MHRD, Govt. of India)  
A-24-25, Institutional Area, Sector-62, NOIDA-201309 (U.P.)

Website: [www.nios.ac.in](http://www.nios.ac.in), Toll Free No: 18001809393

Printed on 60 GSM NIOS Water Mark Paper

---

© **National Institute of Open Schooling**

January, 2019 (1,000 copies)

Published by the Secretary, National Institute of Open Schooling, A-24/25, Institutional Area, Sector-62,  
NOIDA-201309 and Printed at M/s .....

---

## **ADVISORY COMMITTEE**

---

Prof. C. B. Sharma Chairman NIOS, NOIDA (U.P.)	Dr. Rajiv Kumar Singh Director (Academic) NIOS, NOIDA (U.P.)	Dr. Sandhya Kumar Deputy Director (Academic) NIOS, NOIDA (U.P.)
--	--	---

---

## **CURRICULUM COMMITTEE**

---

Prof. Kalpana Sharma Director ASPESS & Sports Amity University, U.P.	Mrs. Sarita Sharma Director ,Yog Sarita Foundation, Delhi	Prof. Ikram Hussain Department of Physical Education A.M.U., Aligarh
Prof. Arvind Malik Head & Professor, Department of Physical Education, Kurukshetra University, Kurukshetra	Prof. Ishwar Bharadwaj Head of Yoga Department Gurukul Kaangri, Haridwar	Dr. Lalit Sharma Associate Professor, IGIPSS, University of Delhi
Mr. S.K.Sinha Director ( Academic) NIOS	Dr. Ashminder Singh Bahal Director (Vocational ), NIOS	Dr.B.K.Rai Assistant Director (Academic), NIOS
	Dr. Azmat Noori Assistant Director (Academic) NIOS	Mr. P.K.Chauhan Senior Executive Officer, (Voca- tional), NIOS

---

## **LESSON WRITERS**

---

Dr. Satish Yadav Assistant Professor Govt. PG College, Gurgaon	Dr. Rakesh Kumar Assistant Professor Gargi College, University of Delhi	Dr. Nidheesh Kumar Yadav Assistant Professor Patanjali University, Haridwar
Dr. Ajit Assistant Professor Amity University, Noida, U.P.	Dr. Jyoti Mann Physical Education Teacher Delhi Administration, Delhi	Dr. Udham Singh Assistant Professor Gokul Kangri University, Haridwar
Dr. Vineet Mehta Director of Physical Education SRCC, University of Delhi	Dr. Arif Mohammand Assistant Professor Jamia Miliia Islamia, New Delhi	Acharya Kaushal Kumar Director Yoga India Foundation, Delhi
Dr. Shubhra Kathuria Director of Physical Education Bharti College, DU	Dr. Arun Kumar Assistant Director, Sport Sharda University, Greater Noida	Dr. Snehalata Domala Associate professor, PG Deptt. of Balarog, VYDS Ayurveda Mahavidyalaya, Khurja (U.P.)
Dr. Meenakshi Assistant Professor IGIPSS, University of Delhi	Ms. Seema Singh Director Integrated Yog Centre, Ghaziabad	

---

## **EDITORIAL BOARD**

---

Prof. Kalpana Sharma Director, ASPESS & Sports Amity University, U.P.	Prof. Ikram Hussain Department of Physical Education A.M.U., Aligarh	Dr. Lalit Sharma Associate Professor, IGIPSS, University of Delhi, Delhi
Mrs. Sarita Sharma Director ,Yog Sarita Foundation, Delhi	Acharya Kaushal Kumar Director Yoga India Foundation, Delhi	Dr. B.B. Paliwal Freelance, U.P.

---

## **COURSE COORDINATOR**

---

Dr. Azmat Noori Assistant Director (Academic), NIOS	Mr. P.K.Chauhan Senior Executive Officer (Vocational), NIOS
--	--

---

## **LASER COMPOSING**

---

M/s. Tessa Media & Computers, C-206, Shaheen Bagh, Jamia Nagar, New Delhi-110025

## *A Word With You*

Dear Learners

National Institute of Open Schooling welcomes its learners to the Senior Secondary Course in 'Physical Education and Yog'. The course includes 'the Concept of Physical Education and Yog', 'Dimensions of the physical education and yog', 'Holistic Health', 'Physical Education and sports sciences' and Yogic practices. This course comprises both theory and practicals. The theory part has been divided into 22 lessons to make it more elaborative.

The study material has been developed for the learners to widen their knowledge, understanding and skills in the field of sports, games and yog asanas. This course provides a chance to the learners to be able to choose physical education and yog as a career. In the present age physical education and yog has gained more importance as people are getting conscious about their health and well being.

The course has been developed in modular form and every module deals with a separate concept. Each module is interlinked with others and motivates the learners to seek more information.

Please note that out of 22 lessons, 06 lessons have been kept apart for you to study and be assessed through Tutor Marked Assignment (TMA) only. These are **Physical Fitness and Wellness** (Lesson No.3), **Career Aspects of Physical Education** (Lesson No.4), **Physical and Physiological Aspects** (Lesson No.5), **Introduction to Health** (Lesson No.9), **Physical Education for Various Populations** (Lesson No.13) and **Asana** (Lesson No.20) that you work upon throughout the year. The public examination (PE) or final exam shall have the lessons other than those earmarked for TMA.

We hope that this course will attract a number of learners and will help them to understand the importance of physical education and especially Yog - that has gained the international acceptance. Physical education and Yog are related to our daily life and makes us proud of our culture.

Your feedback is always welcome. For any kind of suggestion or difficulty feel free to contact us. We shall be more than happy to serve you.

Thanks

Chairman  
NIOS

## How to use the Study Material

Congratulation! You have accepted the challenge to be a self-learner. NIOS is with you at every step and has developed in the material in Physical Education and Yog with the help of a team of experts, keeping you in mind. A format supporting independent learning has been followed. If you follow the instructions given, then you will be able to get the best out of this material. The relevant icons used in the material will guide you. These icons have been explained below for your convenience.

**Title:** will give a clear indication of the contents within. Do read it.

**Introduction:** This will introduce you to the lesson linking it to the previous one.



**Objectives:** These are statements that explain what you are expected to learn from the lesson. The objectives will also help you to check what you have learnt after you have gone through the lesson. Do read them.

**Content:** Total content has been divided into sections and subsections. Section leads you from one content element to another and subsections help in comprehension of the concepts in the content elements.



**Notes:** Each page carries empty space in the side margins, for you to write important points or make notes.



**Intext Questions:** Very short answer self check questions are asked after every section, the answers to which are given at the end of the lesson. These will help you to check your progress. Do solve them. Successful completion will allow you to decide whether to proceed further or go back and learn again.



**What You Have Learnt:** This is the summary of the main points of the lesson. It will help in recapitulation and revision. You are welcome to add your own points to it also.



**Terminal Exercises:** These are long and short questions that provide an opportunity to practice for a clear understanding of the whole topic.



**Do You Know:** This box provides additional information. The text in boxes is important and must be given attention. It is not meant for evaluation, but only to improve your general knowledge.



**Answers :** These will help you to know how correctly you have answered the questions.



**Activities:** Certain activities have been suggested for better understanding of the concept.

**Senior Secondary Physical Education and Yog Course  
Overview of the Learning Material**

<b>Module</b>	<b>Lesson No.</b>	<b>Name of the Lesson</b>	<b>Mode of Assignment TMA/PE</b>	
<b>Module 1 Concept of Physical Education and Yog</b>	1.	Introduction and Historical Development	TMA TMA	PE
	2.	Ethics and Values		PE
	3.	<i>Physical Fitness and Wellness</i>		
	4.	<i>Career Aspects of Physical Education</i>		
<b>Module 2 Dimension of Physical Education and Yog</b>	5.	<i>Physical and Physiological Aspects</i>	TMA	
	6.	Psychological Aspects		PE
	7.	Social Aspects		PE
	8.	Spiritual Aspects		PE
<b>Module 3 Holistic Health</b>	9.	<i>Introduction to Health</i>	TMA	
	10.	Diet and Nutrition		PE
	11.	Awareness of Lifestyle Disorders		PE
	12.	School Health Programme		PE
<b>Module 4 Physical Education and Sports Sciences</b>	13.	<i>Physical Education for Various Populations</i>	TMA	
	14.	Sports Training		PE
	15.	Test and Measurement		PE
	16.	Organization of Tournaments		PE
	17.	Athletic Injuries, First Aid and Safety		PE
<b>Module 5 Yogic Practices</b>	18.	Hatha Yog	TMA	PE
	19.	Shatkarma		PE
	20.	<i>Asana</i>		
	21.	Prāṇāyāma		PE
	22.	Mudra and Bandha		PE

**Total Lesson = 22**  
**Lesson for Public Examination (PE) = 16**  
**Lesson for Tutor Marked Assignment (TMA) = 6**

# Contents

<b>S.No.</b>	<b>Lesson Name</b>	<b>Page No.</b>	<b>Mode of Assignment TMA/PE</b>
<b>Module 4: Physical Education and Sports Sciences</b>			
13.	Physical Education for Various Populations	1	TMA
14.	Sports Training	7	PE
15.	Test and Measurement	15	PE
16.	Organization of Tournaments	21	PE
17.	Athletic Injuries, First Aid and Safety	41	PE
<b>Module 5: Yogic Practices</b>			
18.	Hatha Yog	57	PE
19.	Shatkarma	69	PE
20.	Asana	83	TMA
21.	Prāṇāyāma	97	PE
22.	Mudra and Bandha	113	PE

Content and images adapted from web-based resources in this SLM is being used for educational purposes only and not for commercial purposes.



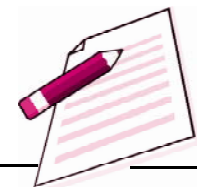


13



373en13

## PHYSICAL EDUCATION FOR VARIOUS POPULATIONS



**Note**

**Read a conversation between student and teacher:**

**Student :** Teacher, my parents are asking me to do some physical exercise for development of my body and mind. But I don't know any kind of physical exercise.

**Teacher :** My child, I will tell you about physical exercise for the development of your body, mind as well as spirit too.

**Student :** Teacher, I am looking forward to know about exercises.

**Teacher :** Physical exercises are the movements or activities performed by our muscles. It includes free play, games, sports, walking, cycling, swimming, and recreational activities. These activities are performed with various intensity and duration for various purposes.

**Student :** It's a wonderful experience to learn about physical exercise. Is the physical activities same for everyone?

**Teacher :** No, there are different exercises and their schedules for various age groups and gender are different.

**Student :** Oh! can you tell me about those exercises for various age groups.

**Teacher :** We cannot give same exercise to everyone for the same purpose. We can divide our activities according to age groups and gender also.

Here in this lesson, we will learn about the physical activities for different population in details.



### OBJECTIVES

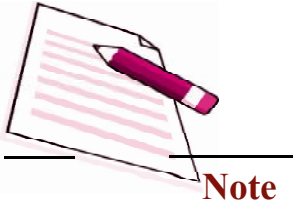
After studying this lesson you will be able to:

- explain the meaning of physical exercise;



*Physical Education and Yog*





- demonstrate physical exercise for children;
- choose the physical exercise for CWSN (Children with special needs);
- choose the physical exercise for women and
- choose the physical exercise for older adults.

### 13.1 MEANING OF PHYSICAL EXERCISE

Physical exercise is a combination of two words. One is ‘physical’ which means “body” and other is ‘exercise’ which means “to do any movement or activity”, so physical exercise means any movement or activity performed by our body. It could be anything such as walking, jumping, throwing, dancing, sports, cycling, etc.

There are lots of benefit of physical exercises. Regular participation in any physical education programme helps in reducing risk of various diseases and leading causes of death. Regular physical activity helps in reducing the risk of heart related problems, diabetes and mainly cancers and depression among females. It builds and maintains the healthy bones, muscles and joints in men as well as in women too.

We all are different from each other in terms of age, height, weight, gender etc. Thus, the need of exercises is different for everyone. Here in the next section, we are going to study what different types of exercise or activity one can perform, which suit his/her requirement.

### 13.2 PHYSICAL EXERCISE FOR CHILDREN

#### Physical Exercise Guidelines for Children (under 5 years)

Active play starts from birth, especially through floor-based activities including tummy-time, reaching, pushing, pulling and crawling. The roots of life long physical exercises are shown in childhood. Children below the age group of 5 must be encouraged especially by their families for regular and routine based exercises. The play game is the very general form of the same. Children of this age do not understand rules and often are not coordinated enough to play organized sports. Walking or running, playing tag, swimming (when at least 4 yrs old), tumbling, dancing, throwing and catching are few activities that can be played in this age group. As they grow older, they might like to try skipping and bike riding.

#### Physical Exercises for Children Ages 5-8

The children of this age group explore relationship between the objects; so the activities including short instruction times, flexible rules, offer free time for



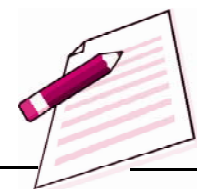
practices, and have fun. These activities must strengthen muscles and bones. For example: Follow the leader (children’s activity game), indoor obstacle course, outdoor obstacle course, musical chairs, playing tag, walking to school, soccer etc.

### Physical Exercises for Children Ages 9-12

Children reach puberty at different times. Physical size, strength and maturity vary widely for this age group. They can easily participate in team sports that focus on skill development, equal participation and fun. They are prepared to start strength training with lighter weights and proper supervision and also perform martial arts, hiking, push-ups (with knees on floor), sit-ups. They can participate in minor games.

### Physical Exercises for Children Ages 13-17

In this age group activities should be fun and include friends. Teens are ready to focus on personal fitness, competitive and non-competitive sports like football, handball, hockey, basketball, cricket, kabbadi and so on. Activities which strengthen bones and muscles and improve their stamina and endurance must include canoeing, hiking, rollerblading, yard work and games that require throwing and catching.

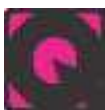


**Note**



#### DO YOU KNOW?

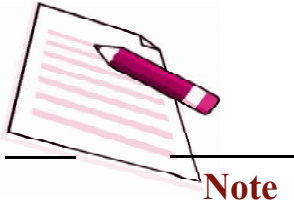
There are lots of benefits of physical activity. It improves cardio-vascular fitness, make bones and muscles strengthen, helps in weight management and stress management, as well as minimize the chance of getting ill.



#### INTEXT QUESTIONS 13.1

- 1) What type of activities should be given to children?  
.....
- 2) Is it advisable to give weight training to the children?  
.....
- 3) What kind of exercises should be given to children of 5-8 years age group?  
.....
- 4) Are the same exercises suitable both for girls and boys up to 10 years of age?  
.....





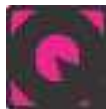
13.3 PHYSICAL EXERCISE FOR OLDER ADULTS

Exercising regularly plays a very important role in maintaining the healthy lifespan in elderly adults. Inactivity leads to weakness and poor balance more than the age factor. The risk of developing dementia is increased in older adults due to inactivity or sedentary lifestyle.

Walking or jogging are the weight bearing exercises which can help in maintaining the strength of bones and thus it reduces the risk of osteoporosis and frequent fracture among the older adults. Exercise also play an important role in decreasing the risk of various chronic conditions, heart disease and diabetes.

Maintenance of cholesterol level within a healthy range decreases the risk of heart disease and stroke which can be avoided with the help of regular exercise.

Most important fear in older adults are fear of falling and that can be managed with proper functioning reach in older adults and with exercise it can be maintained.



INTEXT QUESTIONS 13.2

- 1) List out the exercises suitable for older adult age group.  
.....
- 2) What kind of exercises should be given to sedentary people?  
.....

13.4 PHYSICAL EXERCISE FOR WOMEN

Regular physical activity helps in reducing the risk of various leading causes of death. Regular physical activity helps in reducing the risk of heart related problems, diabetes and mainly cancers and depression among females. It builds and maintains the healthy bones, muscles and joints in women.

Exercise helps to maintain the weight with overall fitness and also prolonged good health.

It is always advised to consult doctors before beginning exercise if one has been inactive for a long period due to any health issues or pregnancy.

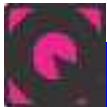
One can only do brisk walking or light exercise for 10 minutes to be active after a long rest.

There are various barriers in physical activity for women as they have lack of time, lack of motivation, lack of energy, parenting and family issues gender stereotyping etc.



**Women can sneak these few exercises in their daily routines:**

- Take stairs instead of using elevators.
- Going for walking whenever free during break time.
- Avoid vehicles and walk down to work place.
- House work may be done quickly, as in fast pace.
- Participate in Cultural activities etc.



**INTEXT QUESTIONS 13.3**

1. List the exercises for females of different age groups.  
.....
2. Why should females do physical exercise? Explain with reasons.  
.....

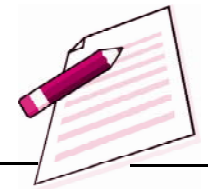
**13.5 PHYSICAL EXERCISES FOR CHILDREN WITH SPECIAL NEEDS (CWSN)**

Physical activities play an important role in development of children with special needs (CWSN). They help to develop specific motor skill, they make new friends, increase aerobic and anaerobic activities. They develop belongingness and self-confidence as the children with disabilities engage less in social and sporting activities compared to their peers. A lot of these children shy away from people, are embarrassed to be even with their peers, and do not participate in activities like sports because of physical challenges and related psychological issues.



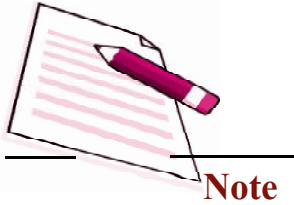
**WHAT YOU HAVE LEARNT**

- Physical exercise is important for everybody including children, older adults, male and female, and persons with disability.
- Best way to maintain health, well-being, and quality of life can be attained with the help of physical activity.
- Physical exercise can improve the various abilities or performance in specially abled children.
- In older adults, it helps to maintain their mobility and ability to function properly with maintaining good mental and physical health.



**Note**





**TERMINAL QUESTIONS**

- 1) Prepare a chart of exercises for teenage children.
- 2) Explain the health benefits of exercises.
- 3) Explain the term disability. Suggest the type of exercises for children with special needs (CWSN).
- 4) Why is physical exercise required daily? Support your answer with arguments.
- 5) Suggest exercise schedule for females working in offices.
- 6) List the exercises for children of 6-10 years age group.
- 7) Explain long term benefits of regular exercises.



**ANSWER TO INTEXT QUESTIONS**

**13.1**

- 1) Kids should be given natural exercises.
- 2) It is not advisable to give weight training to the children.
- 3) Following exercises should be given to 5-8 years age group of children - follow the leader, headstands, indoor obstacle course, outdoor obstacle course, musical chairs, jump rope etc.
- 4) Yes, same exercises for girls and boys up to 10 years of age could be given.

**13.2**

- 1) Exercises for older adult age group are walking, slow jogging, yoga calisthenics exercises etc.
- 2) Exercises for sedentary people are moderate to fast walking for at least 30 minutes, own body weight exercises, light apparatus gym exercises etc.

**13.3**

- 1) Exercises for different female age groups are walking/jogging at moderate speed, light apparatus gym exercises, own body weight exercises, swimming etc.
- 2) Physical exercise for females because they have to carry out daily household routine challenges so they need exercises specially for back and legs region to ease their routine work.



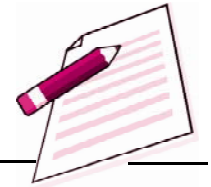


14



373en14

## SPORTS TRAINING



**Note**

Read the conversation between the student and teacher

**Student :** Is there any need for specific training for performance in sports?

**Teacher :** Certainly yes.

**Student :** What type of specific training is required?

**Teacher :** Sports training is systematic training to improve the performance in sports competitions. It includes skill training, physiological conditioning. In this lesson, we will learn about the sports training, fitness and its components and difference between aerobic and anaerobic exercises.



### OBJECTIVES

After studying this lesson you will be able to:

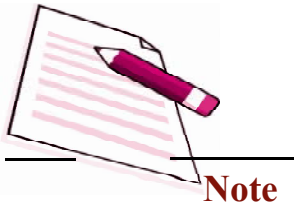
- explain the principles, meaning and aims of sports training;
- explain the fitness and its components and
- describe about aerobic and anaerobic exercises and the difference between them.



### 14.1 MEANING OF SPORTS TRAINING

Sports training is a process of systematic preparation of sportspersons or team to perform well in a sports competition. In this sportsperson or team gets systematic training which is based on scientific principles. The goal of sports training is to train a sportsperson or team to achieve their full potential and perform optimally in a particular competition. Sports training includes- physiological conditioning, psychological training, skill training, and training of game plan or strategy.





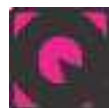
### 14.1.1 Principles of Sports Training

Sports training principles are the guiding forces for coaches or trainer to plan effectively training schedule for sportspersons or team. For an effective use of training principles, it should be taken into consideration for individualized training. Following are the principles of the sports training.

- **Principle of Balance:** This principle broadly focuses on right proportion of each and every performance determinant factor such as physical capacities, psychological makeup, and skill level.
- **Principle of Individualization:** Every human being is different from each-other, so this principle deals with the individual differences. Each training schedule should be designed considering the individual differences.
- **Principle of Overload:** No athlete should be given load beyond his/her abilities.
- **Principle of Recovery:** Ratio of rest and recovery between exercises and time between workouts must be taken care of.
- **Principle of Reversibility:** This principle guides about detraining once athlete discontinues training.
- **Principle of Specificity:** Each sport demands specific requirements and this principle guides regarding game specific requirement.
- **Principle of Transfer:** This principle deals with how the workout performed during the training session can contribute to competitive performance.
- **Principle of Variation:** For obtaining better results of sports training variations in exercises, resting time, and the intensity should be considered.

### 14.1.2 Aim of Sports Training

The aim of sports training is to train an individual or team to achieve top form and perform better and in a selected sport competition. Different factors are responsible for achieving top form of maximum efficiency. Sports training focuses on reaching top form or maximum efficiency.



#### INTEXT QUESTIONS 14.1

- 1) Explain the term 'sports'.

.....





2) Explain the principle of individualization.

.....



### DO YOU KNOW?

Sports performances are affected by the time of day which is known as circadian rhythm.

In the above section you have learnt about the sports training, its principles and its aims. Now we are going to discuss about which physical fitness components are getting trained in sports training.

## 14.2 PHYSICAL FITNESS AND IT'S COMPONENTS

The ability to perform day to day work without undue fatigue may be termed as physical fitness. It encompasses a wide range of abilities so that one can carry out daily routine with ease and overcome the physical challenges during sports competitions.

### 14.2.1 Physical Fitness Components

These are basic components which make athlete fit for sports. Let us learn more about components of physical fitness.

**Strength:** It is an ability of a muscle to overcome resistance. Strength is mainly of three types.

**Maximum Strength:** It is an ability of a muscle to overcome maximum resistance.

**Strength Endurance:** It is an ability of the muscle to carry out resistance for longer duration of time.

**Explosive Strength:** It is an ability of the muscle to overcome resistance in possible time.

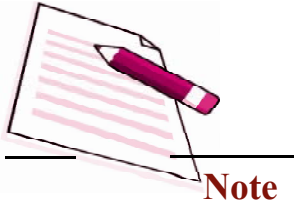
**Endurance:** It is the ability to perform activity with desired quantity and quality under condition of fatigue. Like continuous running for 15 minutes and above is best example of endurance. Endurance may be divided into cardiovascular endurance and muscular endurance.

**Speed:** It is the ability to cover a distance or perform any action in minimum possible time. Speed may be divided into five sub components which are as follows:



### Note





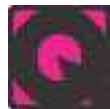
**Note**

- a) Reaction Ability,
- b) Movement Speed,
- c) Acceleration Ability,
- d) Locomotor Ability, and
- e) Speed Endurance.

**Flexibility:** It is the ability of joints to move full range of motion (ROM). Flexibility is also two types. One is Active Flexibility and the second is Passive Flexibility.

**Coordinative Abilities:** Ability to quickly and respectfully doing a group of movements with better quality and effect. There are following coordinative abilities:

- a) Orientation Ability
- b) Coupling Ability
- c) Balance Ability
- d) Differentiation Ability
- e) Rhythmic Ability, and
- f) Reaction Ability.



**INTEXT QUESTIONS 14.2**

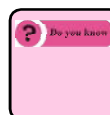
Fill in the blanks with appropriate word.

- 1) Flexibility exercises improve ..... at a joint.
- 2) Strength exercises include ..... exercises.
- 3) Squats are used for strengthening .....



**ACTIVITY 14.1**

Prepare a chart by collecting pictures of ‘upper body strength exercises’.



**DO YOU KNOW?**

To increase overall physical capabilities (endurance), a person should be given certain amount of stress (overload).



In the above section you have learnt about the components of physical fitness. Now in the next section you will learn the exercises you can use to train above mentioned components.

### 14.3 AEROBIC AND ANAEROBIC EXERCISES

It is often said that exercises cannot be performed without oxygen. To some extent it is true. When exercises are performed for the longer period of time, constant supply of oxygen is required. Whereas certain exercises are performed as ballistics movement or separated in shorter span of time. Such activities do not require constant supply of oxygen. Basic difference in aerobic and anaerobic can be understood by discussing further about aerobic and anaerobic exercises.

#### Aerobic Exercise

Aerobic exercises are the exercises which are performed with the oxygen and glucose and fat used as fuel. Aerobic activities can be sustained for a longer period of time. Some of aerobic activities are slow and continuous running or jogging.

#### Anaerobic Exercise

Anaerobic exercises are performed where the constant supply of oxygen is not present. Examples of anaerobic exercises are short distance running like 100 meters. While performing anaerobic exercise our body generates lactic acid which causes fatigue at sustained levels term.

#### Differences in Aerobic and Anaerobic Exercises

Aerobic exercise	Anaerobic exercise
Involves oxygen in energy production	Doesn't involve oxygen in energy production
May last longer than 2 minutes	Lasts from a few seconds to 2 minutes, then a pause is required
Increases endurance, improves cardiovascular system	Increases strength, improves bone density, builds up muscles

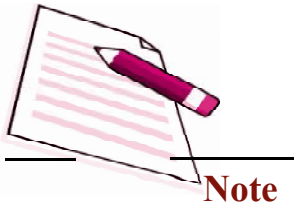
#### 14.3.2 Process of Determining Aerobic or Anaerobic Fitness

For determining the kind of exercise you are performing, you can use your maximum heart rate (MHR) to calculate which exercise you are performing.



**Note**





To calculate Maximum Heart Rate (MHR):

$$220 - \text{age} = \text{MHR}$$



Figure: Showing different heart rate zones



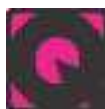
**DO YOU KNOW?**

One needs to exercise at 55-85% of your max heart rate (max heart rate per individual is 220-your age) in order to improve one's aerobic fitness.



**ACTIVITY 14.2**

Prepare chart by collecting pictures of five Aerobic and five Anaerobic exercises.



**INTEXT QUESTIONS 14.3**

Complete the sentences in a meaningful way

- 1) Aerobic exercises are performed with .....
- 2) Anaerobic exercise can not be performed without .....
- 3) Maximum heart rate is calculated by .....



**WHAT YOU HAVE LEARNT**

- Sports training is a process of systematically preparing of sportsperson or team to perform well in a sports competition.



- Sports training principles are the guiding forces for coaches or trainers to plan effectively training schedule for sportspersons or team. The principles of the sports training are- Principle of Balance, Principle of Individualization: Principle of Overload, Principle of Recovery, Principle of Reversibility, Principle of Specificity, Principle of Transfer, and Principle of Variation.
- The aim of sports training is to train an individual or team to achieve top form and perform better in a selected sport competition.
- The ability to perform day to day work without undue fatigue may be termed as physical fitness.
- Aerobic exercises are performed for the longer duration of time and with the constant supply of oxygen.
- Anaerobic exercises are performed for shorter duration and in the absence of oxygen for very short period of time.

**Note****TERMINAL QUESTIONS**

- 1) Explain the meaning of sport training and list its principles.
- 2) Explain the components of physical fitness.
- 3) Differentiate between aerobic and anaerobic exercises.
- 4) Explain load and recovery principle in sports.

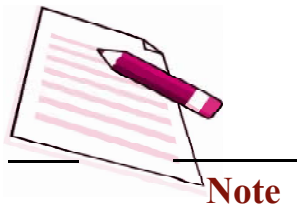
**ANSWER TO INTEXT QUESTIONS****14.1**

- 1) Sport is a vigorous competitive activity where a player finds his full of satisfaction and achievement.
- 2) Individualization Principle concerns adjustments in training based on differences between individual athletes.

**14.2**

- 1) Flexibility exercises improve range of motion at a joint.
- 2) Strength exercises include weight training exercises.





3) Squats are used for strengthening thigh muscles.

### 14.3

- 1) Aerobic exercise could be performed in presence of Oxygen.
- 2) Anaerobic exercise could not be performed without Oxygen.
- 3) Maximum heart rate is calculated by  $220 - \text{age}$ .



15



373en15

## TESTS AND MEASUREMENTS

Read the conversation between the student and teacher.

*Student-* Good Morning Sir.

*Teacher-* Good Morning Rohan.

*Student-* What is going on Sir?

*Teacher-* I am measuring student's height and weight

*Student-* Sir, why do we want to measure height and weight?

*Teacher-* It's a part of routine check-up, and its comes under test and measurements.

*Student-* Oh, can you tell me more what is test and measurement?

*Teacher-* Test and Measurement is the means by which we can find different abilities and student's current physical condition.

Dear learner, in this lesson we are going to discuss the meaning of test and measurement, what is its need and importance as well as testing procedure of physical fitness components.



### OBJECTIVES

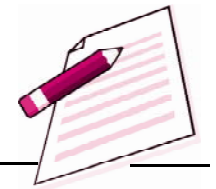
After studying this chapter you will be able to:

- explain the meaning of test and measurement;
- explain the need & Importance of test and measurement and
- do the measurement of components of physical fitness.



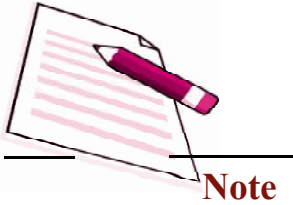
### 15.1 MEANING OF TEST AND MEASUREMENT

Test and measurement have a very important role in the field of physical education. Test and Measurement are the means by which we can explore the needs, abilities, qualifications and many other important information of students. The effect of training and coaching can be determined by the test and



**Note**





measurement. The progress made by the player can be measured and accordingly future plan may be designed. Finally, we can say that it is not possible to achieve the desired goals unless you know the progress. Therefore, knowledge about test and measurement is essential.

**Test**

A test is a tool having a set of questions and an examination. It is used to measure a particular characteristic of an individual or a group of individuals. It is something which provides information regarding individual’s ability, knowledge, performance and achievement



**DO YOU KNOW?**

According to Barrow and McGee:

“A test is a specific tool or procedure or a technique used to obtain response from the individuals in order to gain information which provides the basis to make judgment or evaluation regarding some characteristics such as fitness, skill, knowledge and values.”

A test is a tool which is used to evaluate the physical fitness, skill and performance of a sports person. For example, we use for measuring height- Stadiometer, measuring weight- Weighing Machine, and body temperature- Thermometer



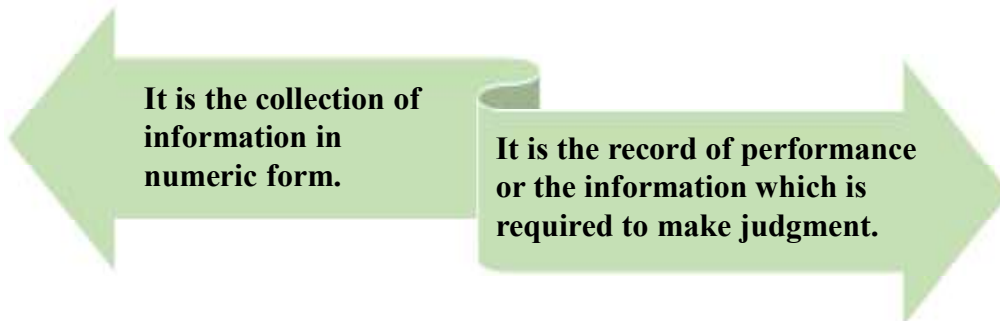
“Test is a specific tool. Procedure or method used to elicit a response from the student in order to gain information as a basis for appraisal of the quantity or quality of elements such as fitness, skill, knowledge and values.”

**MEASUREMENT**


Measurement refers to the process of administration of a test to obtain a quantitative data. It can also be said that measurement aids evaluation process in which various tools and techniques are used in the collection of data.








**Note**

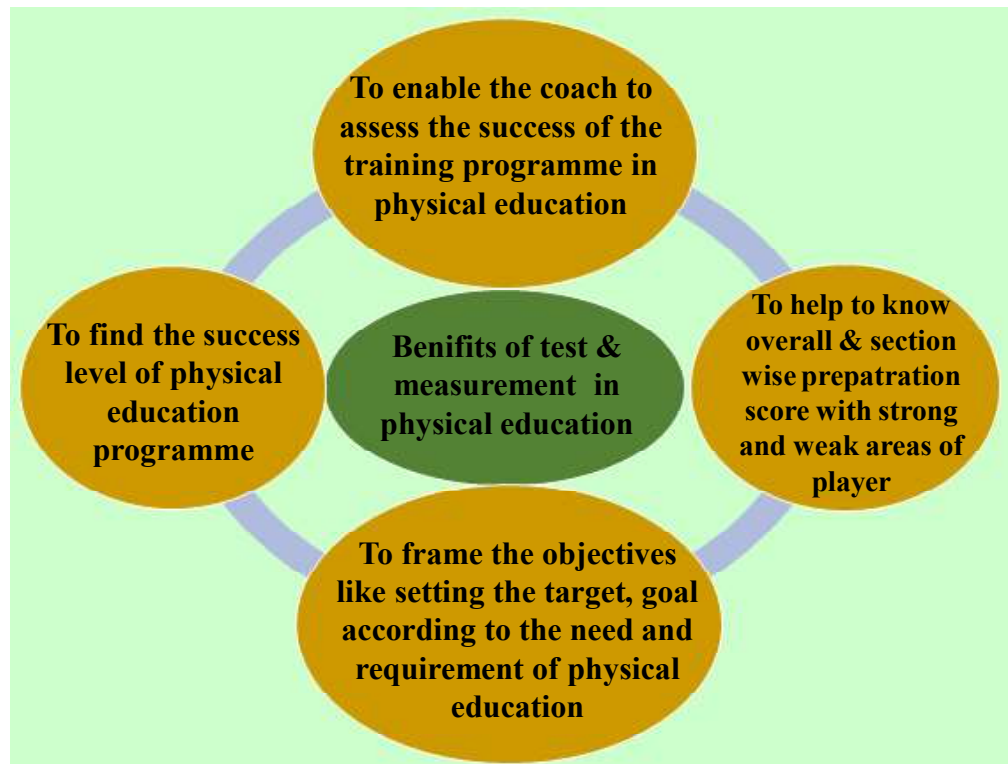
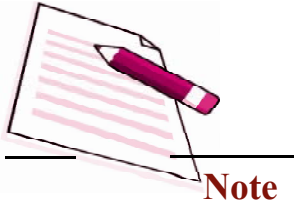
 <b>DO YOU KNOW?</b>	<p>According to R.N.Patel;</p> <p>“Measurement is an act or process that involves the assignment of numeric values to whatever is being tested. So it involves the quantity of something.”</p>
--	--

<p>“Measurement is a process by which levels of performance, fitness, knowledge, personality and skill are determined with the help of various standard tests.”</p>	
---	---

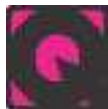
## 15.2 NEED AND IMPORTANCE OF TEST AND MEASUREMENT

- Every Individual has a different quality, capacity, strength and weakness. It helps to select appropriate learning situation according to them.
- To predict potentials and future performance
- To conduct a research and, prepare new norms and standards
- To evaluate the teacher, coach and trainer and their teaching programme and training method.
- To evaluate the learner from time to time and find his or her progress, weakness and current fitness status so that a learner can be placed in to the appropriate training group
- For the purpose of guidance and counselling of an athlete and motivate him to do better





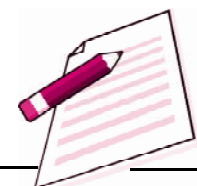
- It helps in classification or gradation of learner and makes it easy for teacher/ coach in selection of athlete
- To diagnose the learning problem of an individual and discover his need
- To find the success level of physical education programme
- To study the individual’s development



**INTEXT QUESTION 15.1**

- 1) explain the term 'test' as applied in physical education.
- 2) Explain the meaning of measurement.
- 3) Fill in the Blanks with appropriate words.
  - a) A test is a ..... which is used to evaluate the skill, performance and reliability of task completed by a sports person.”
  - b) Measurement is..... of performance or the information which is required to make judgment.
  - c) To study the individual’s development..... of test & measurement.
  - d) .....is the collection of information of numeric form.





**Note**

4) Match the following statement of column A with the facts given in column B in a meaningful manner.

1) To evaluate the teacher, coach and trainer and their teaching programme/ training method.	A) R.N.Patel
2) “Measurement is an act or process that involves the assignment of numeric values to whatever is being tested. So it involves the quantity of something.”	B) Test and Measurement
3) The effect of training and coaching can be determined by	C) Need and Importance of Test & Measurement

**15.3 COMPONENTS OF PHYSICAL FITNESS**

Physical fitness comprises of 5 components which are as follows:

- 1) Strength
- 2) Endurance
- 3) Flexibility
- 4) Speed
- 5) Coordinative abilities.

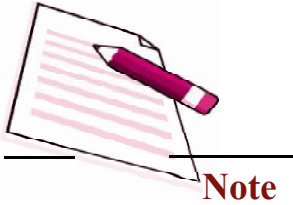
**Note:** You will learn definition of the above mentioned components in details in lesson No 3 Physical Fitness and Wellness and Lesson No 4 Sports Training. The practical manual will describe the assessment procedures.



**WHAT HAVE YOU LEARNT**

- Test and measurement have a very important role in the field of physical education.
- Through measurement we can explore the ability, qualification and important information of students.
- Physical fitness components can be measured by using specific tests.
- Measurement is a process of assigning numeric values to the component which is being tested.





- Component of physical fitness are muscular strength, muscular endurance, flexibility, cardio-vascular endurance.



TERMINAL QUESTIONS

- 1) Explain the need and importance of test and measurement.
- 2) Explain the components of physical fitness.



ANSWERS TO INTEXT QUESTIONS

15.1

1. Test may be called as a tool, which is used to measure a particular characteristic of an individual or a group of individuals. It is something which provides information regarding individual's ability, knowledge, performance and achievement
2. Measurement is a process by which level of performance, fitness, knowledge, personality and skill are measured with the help of various standard tests.
3. Fill in the Blanks  
**a-Tool, b-Record, c- Need & Importance, d-Measurement.**
4. Match the following statement of column  
 1-C, 2-A, 3-B



16

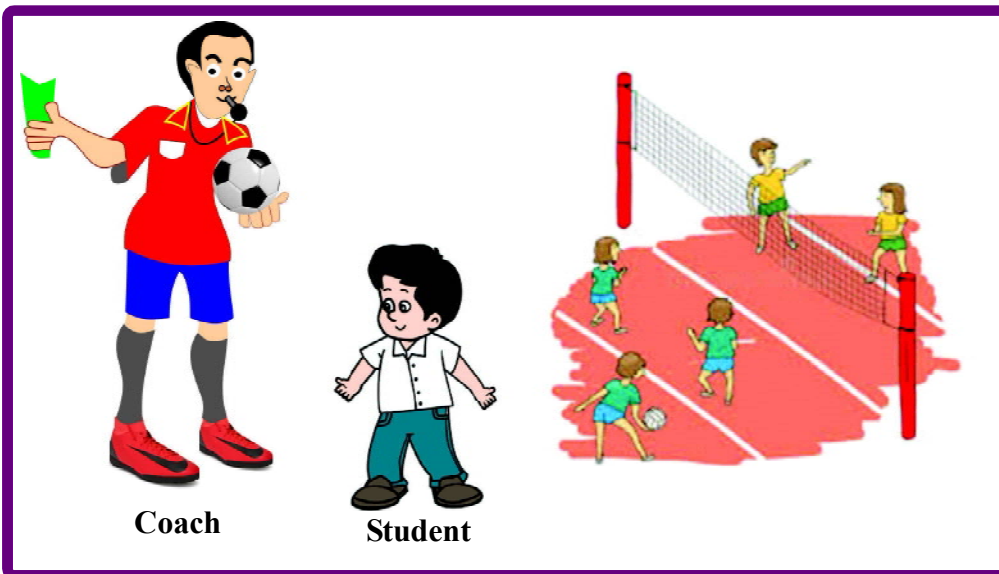


373en16

ORGANIZATION OF TOURNAMENT



Note



Coach

Student

Read the conversation between student and coach.

**Student :** Good Morning Coach.

**Coach :** Good Morning Vikas.

**Student :** Sir, are we organizing some tournament?

**Coach :** Yes, Vikas we are Organizing a volleyball tournament.

**Student :** Can you tell me, what is a Tournament?

**Coach :** Yes, of course. A Tournament is a series of games or matches that are used to decide the winner of a competition.

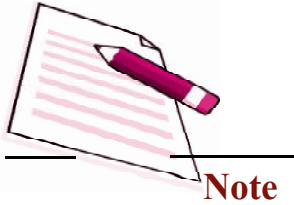
**Student :** Oh!

**Coach :** In sports a tournament is often used at the conclusion of the season to crown the league’s champion.

**Student :** Thank you Coach.

Dear learner, in this lesson you will learn about meaning, definition and importance of tournament, types of tournaments, and how tournaments are conducted.

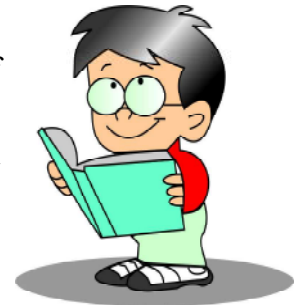




**OBJECTIVES**

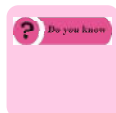
After studying this chapter you will be able to:

- explain the meaning, definition and importance of Tournament;
- describe the different types of tournament and draw fixtures;
- learn how tournaments are conducted and
- describe the intramural and extramural.



**16.1 MEANING AND DEFINITIONS OF TOURNAMENT**

A tournament is a series of games or matches that are used to decide the winner of a competition. In sports, a tournament is often used at the conclusion of the season to crown the league’s champion. Tournaments are usually conducted over a short time period. In addition to sporting events, tournaments are often staged for card games like poker, rummy and bridge. The tournament format indicates the matchups and the criteria for advancement and elimination.



**DO YOU KNOW?**

According to “John Cannon’s Dictionary of British History,” tournaments began as military competitions. The first tournament were equestrian and military competitions that were held in Europe at around the year 1000.

**“A competition for teams or single players in which a series of games is played, and the winners of each game play against each other until only one winner is left”**

**“A competition involving many competitors in a single sport or game is Called Tournament”**

**Participation in a tournament proves player’s capabilities.**

- Tournament provides an opportunity to demonstrate game skills.
- Tournaments is a powerful medium of popularize a particular game or sports.



- Tournaments are the greatest source of motivation for further effort and for life.
- Tournaments are a great medium to popularize a particular game and sports.
- Tournaments motivate the people towards the sports.
- Competitions\ and Tournaments provide a healthy entertainment of people.
- Tournaments help the players to monitor the level of their performance and evaluate their standards of achievement
- Participation in a tournament relieves the players.
- Tournament/competitions have become a big money spinner.



**Note**

**16.2 TYPES OF TOURNAMENT**

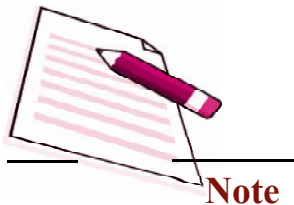
There are various types of tournaments. Some of the important tournament are listed below;



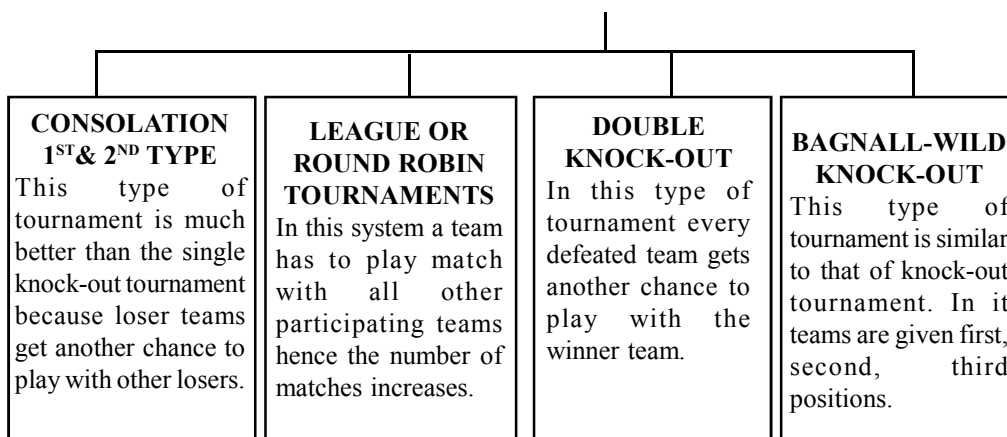
**Knock- out Tournaments-** In knock-out tournament a team continues to play further matches as per schedule till defeated.





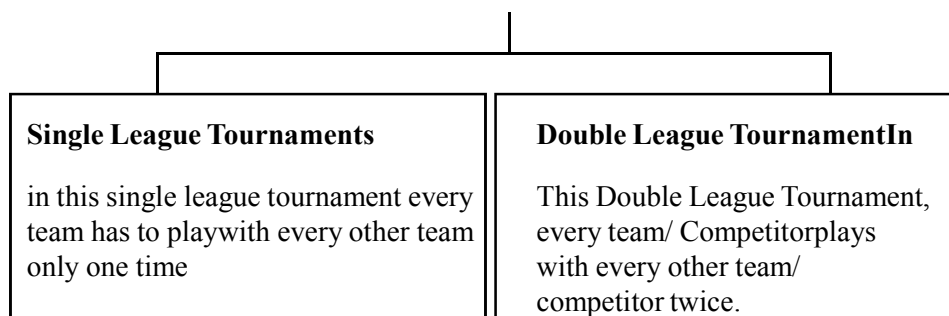


### KNOCK-OUT TOURNAMENT



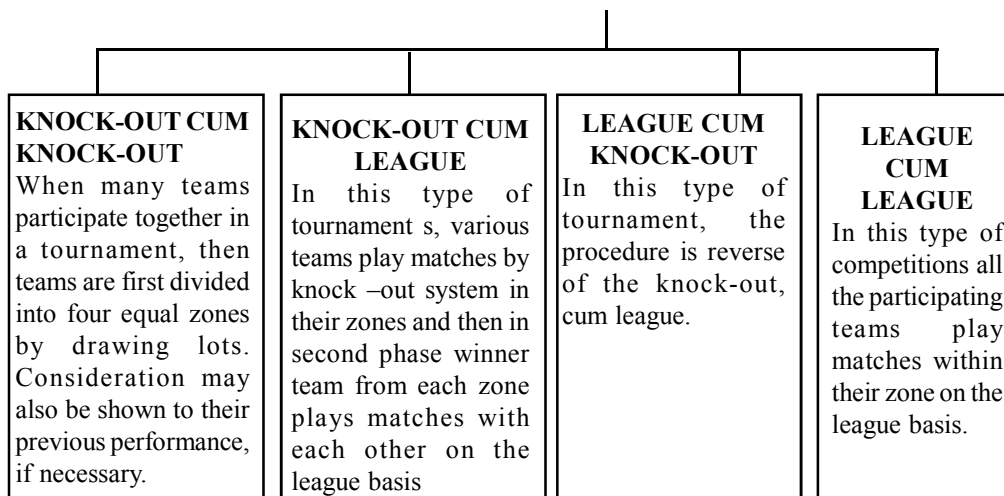
**League Tournaments-** In this system a team has to play match with all other participating teams hence the number or matches increase.

### LEAGUE OR ROUND ROBIN TOURNAMENT



**Combination Tournament-** This type of tournament involves a combination of knock-out and the league system depending upon the suitability of the activity.

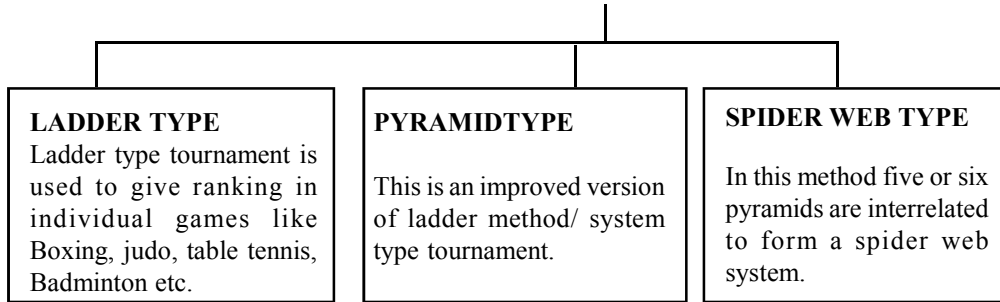
### COMBINATION TOURNAMRNT





**Challenge Tournament-** In this method lower seeded players give challenge to higher seeded player. Thus challenge round goes till the last player. These types of tournament are usually organized for Wrestling, Table tennis, Badminton, Archery , Squash etc.

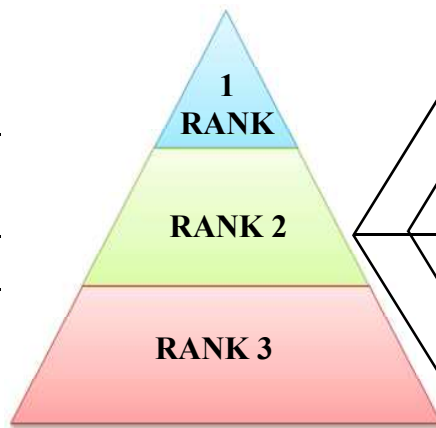
### CHALLENGE TOURNAMENT



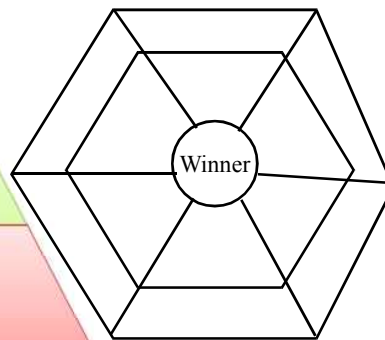
**Note**

Places	Players	Places
1	A	
2	B	
3	C	
4	D	
5	E	
Places		Places

Ladder Type



Pyramid Type

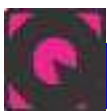


Spider webType



**DO YOU KNOW?**

RANK 3's player can challenge the player of rank 1 or rank 2. If he wins then the ranks of both the players will change among themselves.



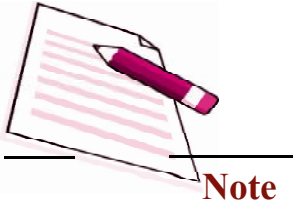
**INTEXT QUESTION 16.1**

1. Explain the meaning of tournament.

.....

.....





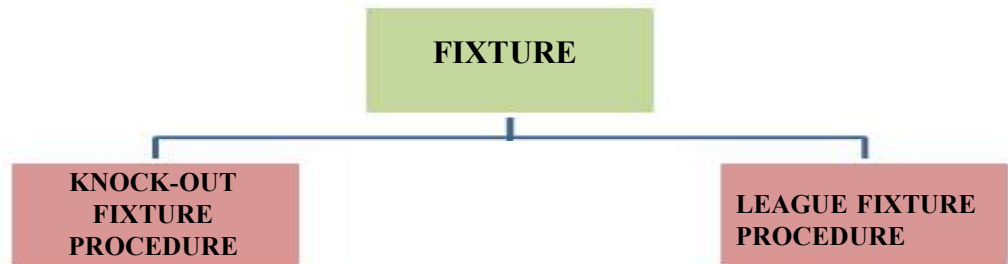
2. List down the types of tournament.  
.....
3. Explain the importance of tournament.  
.....
4. Explain round robin tournament.  
.....

**16.2.1 Procedure to Draw of Fixture**

**WE CAN SAY**  
 “Fixture is a planned process of a tournament to be played. Fixture may be defined as schedule of the teams taking part in the tournament and the methods of deciding the course of competition”.



Here we will discuss two types of main fixture procedure



**Knock-out Fixture Procedure-** In this type of fixture a team will be eliminated immediately after defeat. It has less number of matches as compare to other types of fixture procedure, thus easy to conduct



**DO YOU KNOW?**

The success of the tournaments fully depends upon suitable fixture. Tournaments are played in various forms of fixture. Setting up the fixture means, making arrangement of competitions among teams.  
 “Fixture is a process of arranging the teams in systematic order in various groups for competitive fights for physical activity”



### 16.2.2 Procedure of Knock-out Fixture

First we have to determine the number of teams in upper half and lower half:

In case of even number of teams:

$$\text{Teams in upper half will be: } \frac{n}{2}$$

For 12 Teams

$$\text{Teams in upper half} = \frac{n}{2} = \frac{12}{2} = 6$$

Means, there will be 6 teams in upper half and 6 team in lower half

In case of odd number of teams:

$$\text{Teams in upper half will be: } \frac{n+1}{2}$$

$$\text{Teams in lower half will be: } \frac{n-1}{2}$$

For 13 Teams

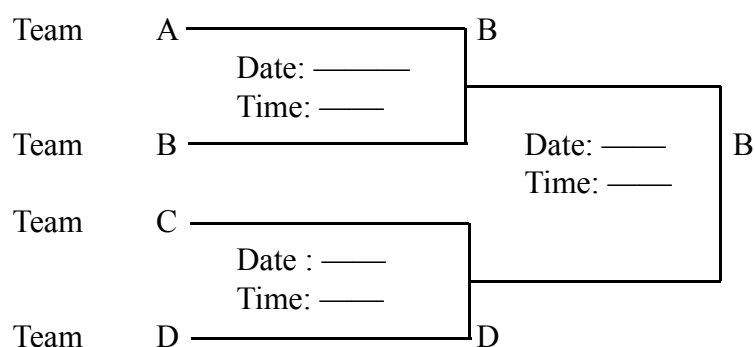
$$\text{Teams in upper half} = \frac{n+1}{2} = \frac{13+1}{2} = \frac{14}{2} = 7$$

$$\text{Teams in lower half} = \frac{n-1}{2} = \frac{13-1}{2} = \frac{12}{2} = 6$$

Means, there will be 7 teams in upper half and 6 teams in lower half

**If number of teams are 2,4,8,16,32, ....then there is no need of 'bye'.**

i) Total Number of teams = 4

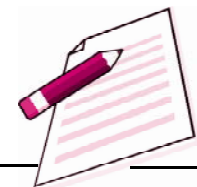


Exploration : Match between A Vs B won by B

Match between C Vs B won by D

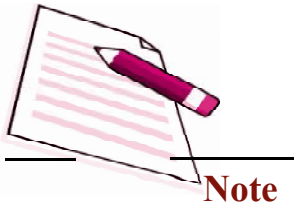
Final match held between B Vs D won by B

Round I                  Round II

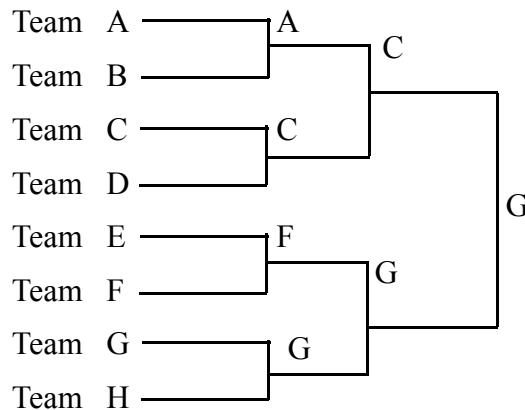


**Note**





ii) Total Number of Team = 8



Explanation Match between A Vs B won by A in Round one  
 Match between C Vs D won by C in Round one  
 Match between E Vs F won by F in Round one  
 Match between G Vs H won by G in Round one  
 Match between A Vs C won by C in Round Two  
 Match between F Vs G won by G in Round Two  
 Final Match between C Vs G won by G in Finals

**Bye is advantage to a team to exempt to play first round, generally given by drawing lots system.**

If the number of teams are not the lower of 2 (Two) then we will follow different method.

we have to determine the “Byes”

Formula of bye: = Next power of two from total number of teams – total number of teams

**Example:**

Next power of two from total number of teams	total number of teams	Number of Byes
8	7	1
16	11	5
32	21	11

**Allotment of byes to teams**

First bye will be given to last team of lower half, Second bye will be given to first team of upper half. Third bye will be given to last team of first half and fourth bye will be given to first team of lower half. After that same pattern will be followed.

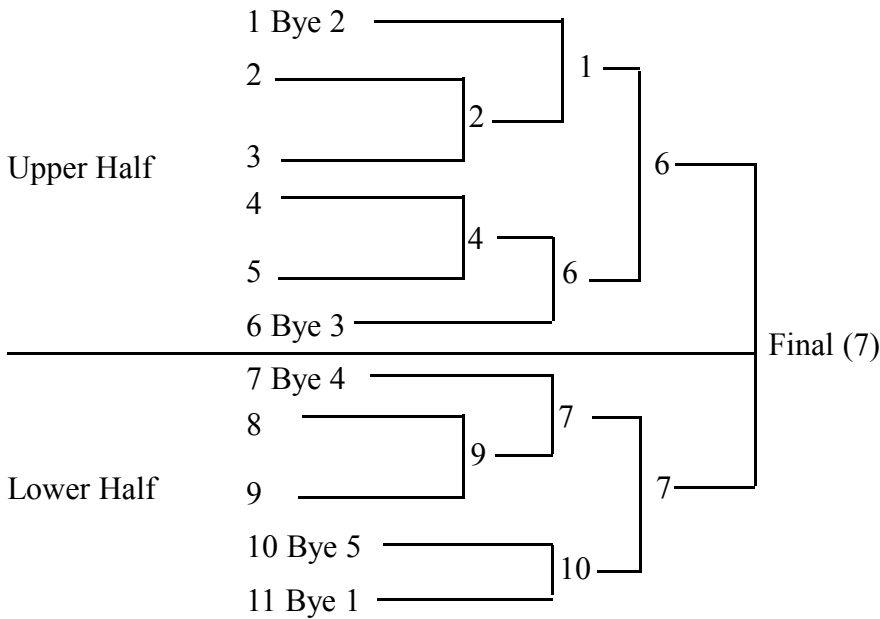


Total Number of team = 11 (Odd Number)

$$\text{Total Number of team in Upper half} = \frac{n+1}{2} = \frac{11+1}{2} = \frac{12}{2} = 6$$

Number of byes :  $16 - 11 = 5$

Teams R<sub>1</sub> R<sub>2</sub> R<sub>3</sub> Finals

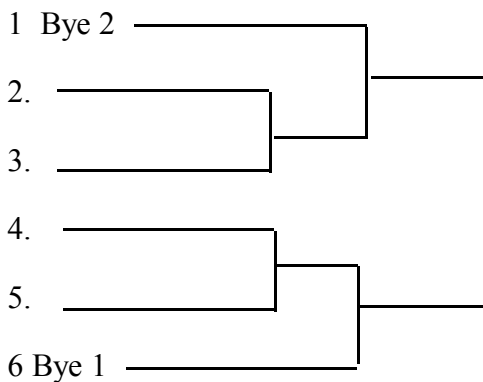


Total Number of Teams = 6 (Even Number)

$$\text{Number of teams in upper half} = \frac{n}{2} = \frac{6}{2} = 3$$

Number of byes :  $8 - 6 = 2$

Teams R<sub>1</sub> R<sub>2</sub> Finals

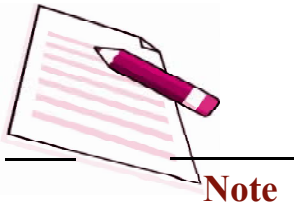


R = Round







**Note**





**Advantage of knock-out Fixture Procedure**

 <p>Less Expensive</p>	 <p>Less Time needed</p>	 <p>Less tiredness to players</p>	 <p>number of organizers required</p>
---	---	---	--

**Disadvantage of Knock-out Fixture Procedure**

 <p>High Stress on Players</p>	 <p>Good Team May Eliminated</p>	 <p>Selection of Players is difficult</p>
---	---	--



**DO YOU KNOW?**

**“BYE”:** - A bye is a special privilege given to a team in the initial rounds because of which it gets exempted from playing in the first round and directly enters the second round.

**Seeding:** - Seeding is given to some special teams or those teams which are winner/runner up teams of the last year’s tournament.

**Special seeding:** - In this type if seeding the seeded players are brought straight away to quarter-finals or semi-finals.

**16.2.3 Single League or Round Robin**

In single League or Round robin fixture every team will play with every team of the tournament.

Formula to determine the number of matches (7 teams):

$$\text{Total number of matches} = n(n-1)/2 = 7(7-1)/2 = 7(6)/2 = 42/2 = 21 \text{ matches}$$



Ist Round	2nd Round	3rd Round	4th Round	5th Round	6th Round
A-B					
A-B	B-C				
A-B	B-D	C-D			
A-B	B-E	C-E	D-E		
A-B	B-F	C-F	D-F	E-F	
A-B	B-G	C-G	D-G	E-G	F-G

**League Fixture procedure:-** In this type of fixture each team plays with every other team at least once if it is single league fixture procedure tournament but in case of double league fixture procedure tournament, every team plays without consideration of winning or defeat in a match.

**League Fixture**

- Single Laegue
- Double Laegue

Fixture of 7 teams in Single League tournament where teams are represented by alphabets A to G. The number of matches are 21. For winning team is given 2 points, for loss no point and for draw 1 point is awarded. A Gerward final score is compared to decide winner of tournament.

**ACTIVITY 16.1**

Make a league fixture of 8 teams

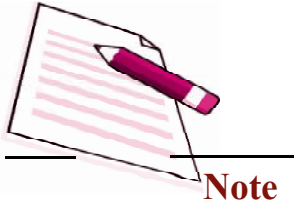
**Advantage of league fixture Procedure**

  <p>Selection of Skilled Players is very easy</p>	 <p>Strong Team Can Win</p>	 <p>Players Interest</p>	 <p>Overcome lacking</p>
--	--	---	--



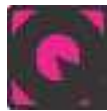
**Note**





**Disadvantage of League Fixture Procedure**

 <p><b>Time Consuming</b></p>	 <p><b>Lot of Injuries</b></p>	 <p><b>Complicated scoring</b></p>	 <p><b>Less interest players and Spectators</b></p>
--	---	--	--



**INTEXT QUESTION 16.2**

1. Explain the advantage of knock-out fixture.  
.....
2. What is Seeding?  
.....
3. What is special seeding?  
.....

**16.3 HOW TO CONDUCT A TOURNAMENT**

**Pre-Tournament Preparation**

- A-After finalizing the event we also prepare a budget and finalizing the dates and venues.
- B-Arrangement of the equipment and playfields.
- C-To provide information of the tournament to the participating teams.
- D- Make the fixture and events rules and regulations.
- E-Accommodation arrangement for students & referees.
- F-Arrangement of trophies, Medal, Certificate etc.,
- G-Arrangement of transportations

**During - Tournament Preparation**

- A-Check all the equipment, ground facilities before starting the events.
- B-Check all players' eligibility of players and other officials.
- C-Provide first- aid to injured players.
- D-Prepare matches result, score sheet or press release.
- E-Supervise and check smooth working officials & matches conducted on fixture bases.
- F-Provide refreshment, meals, transportation to officials and players.
- G-Check and maintain discipline among spectators.





**Post-Tournament Preparation**

- A-Check the departing teams, refund security money and other related documents.
- B-Present the Medal, Merit certificate, Trophy to the position holder’s players.
- C-Make the payments of officials and other bodies.
- D>Returns the borrowed things to the concerned ones.
- E-Make a final press release report.
- F-Make a final event report and present to authority.
- G- Distributing the certificate of participating team.



**Note**

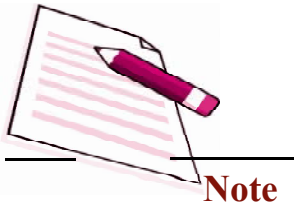


**INTEXT QUESTIONS 16.3**

- 1) Fill in the Blanks
  - a) Ladder type tournament is type of .....
  - b) Knock out – cum league tournament is the type of.....
  - c) Double league tournament is the type of .....
  - d) Consolation 1<sup>st</sup> and 2<sup>nd</sup> type tournament is the type of .....
- 2) Match the following statement of column

1- Provide the opportunities to demonstrate game skill	A- These types of tournament are usually organized for Wrestling, Table Tennis, Badminton, Archery, Squash etc.
2- Combination tournaments	B- This type of tournament involves a combination of knock-out and the league system depending upon the suitability of the activity.
3- League cum knock-out tournaments	C- Importance of tournament.
4- Challenge tournaments	D- Type of tournaments





### 16.4 INTRAMURAL

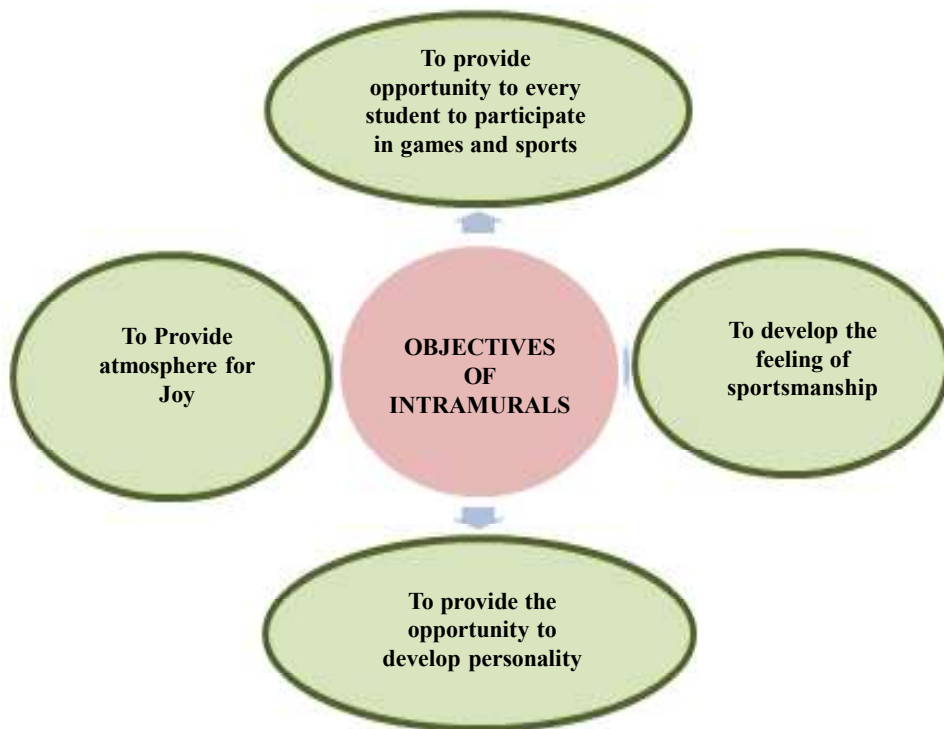
The word “Intramural” is a combination of two Latin words “intra” and “murus”. Intra meaning is ‘within’ and Murus meaning is ‘wall’. Intramurals activities should form the basis of all programmes and competitions. All students should be provided opportunities to compete regardless of their skills. Intramurals received the major attention as part of physical education programme of a school. The intramurals programme may also be viewed from a different angle. Intramurals should be under the direction of the physical education department of a school; and participation of the student may be taken as taking part in general activities such as music, debate, dance, public speaking, and dramatics. Few of intramural level competitions like Inter-Class, Inter-House, and Inter-Hostel etc.



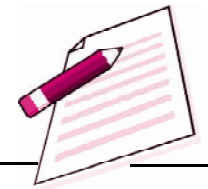
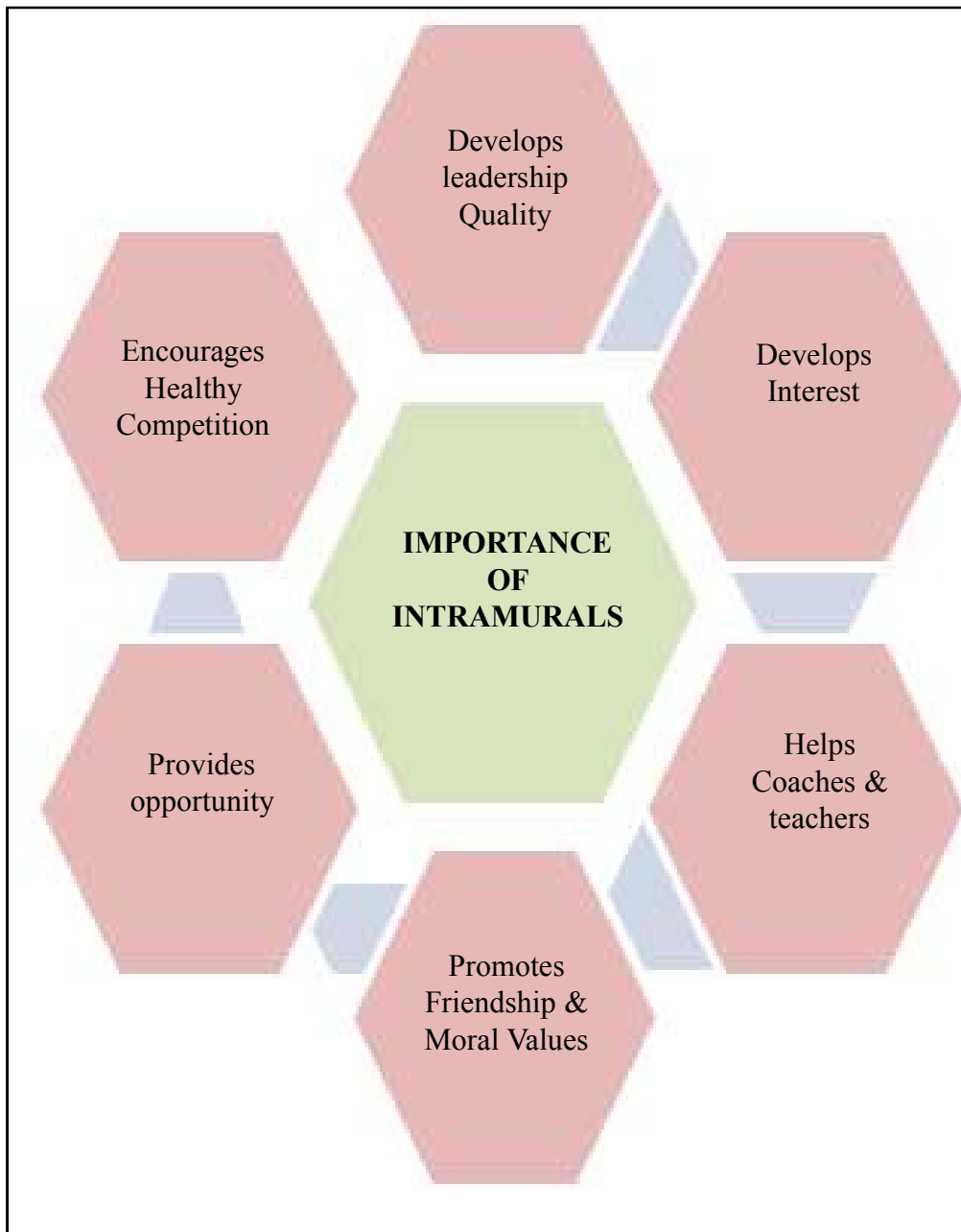
#### DO YOU KNOW?

“A game for each and each for a game” may be taken up as its motto.

#### Objectives of Intramural



### Importance of Intramural

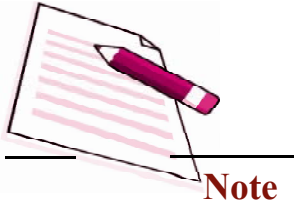


#### Note

#### 16.4.1 Extramural

Extramural sports would involve competitions with teams outside of your own institution or school. Extramural competitions are to find the talented players and to give exposure to good player at upper level. Few of extramural competitions like Inter -school, Inter-college, Inter-District, State, and National and Inter-National level.

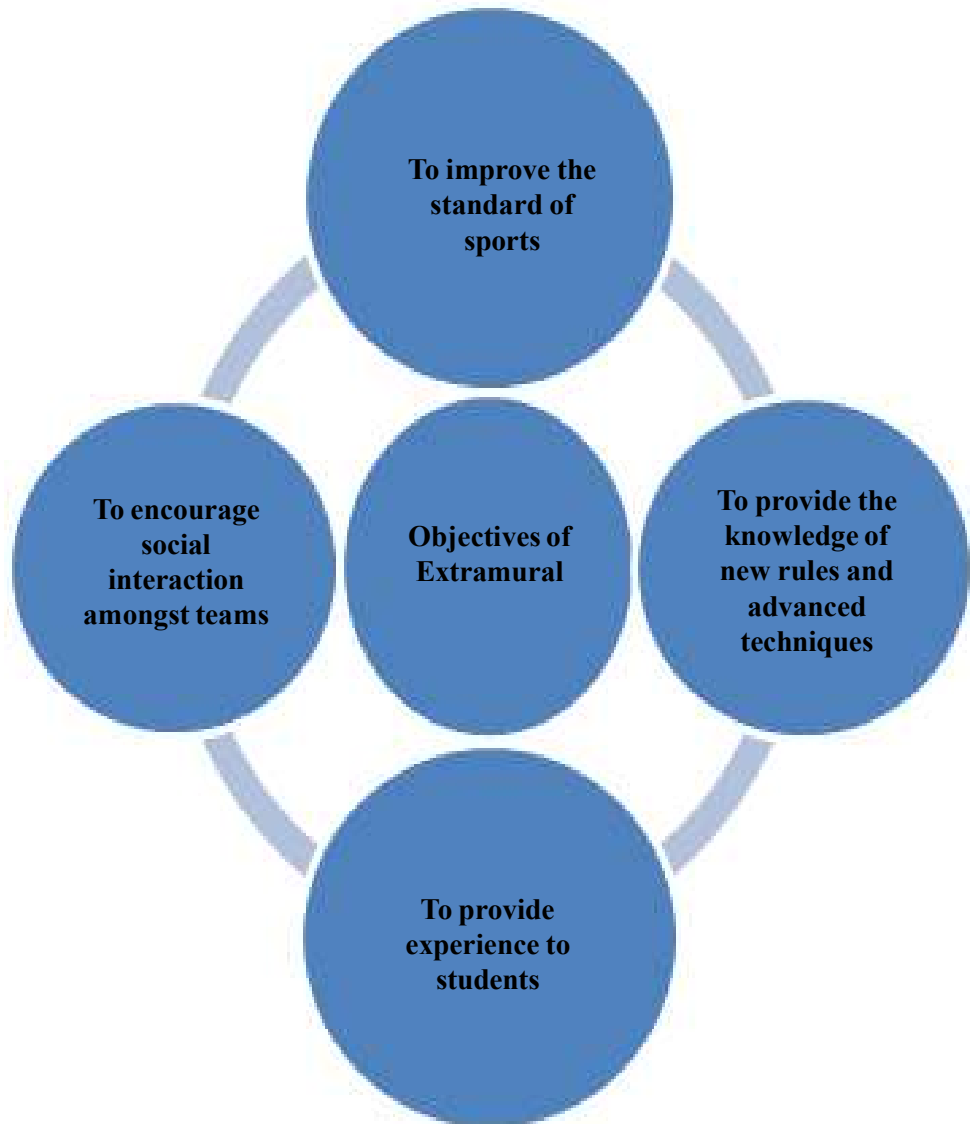




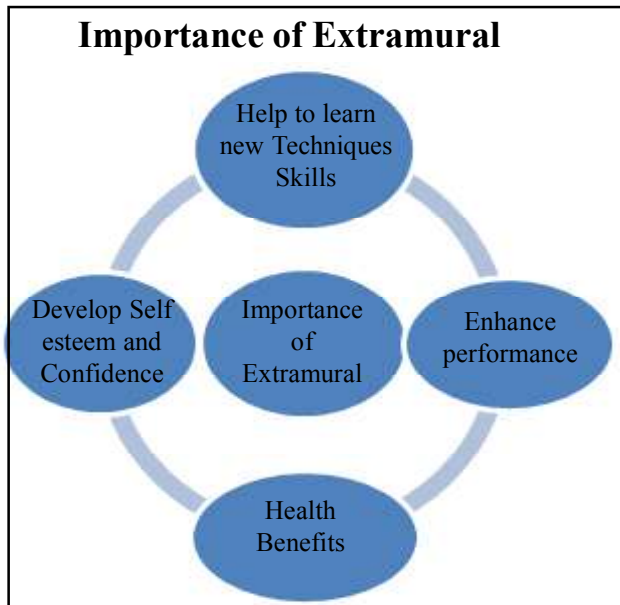
**DO YOU KNOW?**

The word “extramural” is also a Latin word “Extra” meaning “Outside” or “beyond” the wall.

**Objective of Extramural**

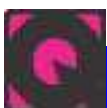


**Difference between Intramural and Extramural**



**Note**

<b>Intramural</b>	<b>Extramural</b>
<b>Intramural</b> competitions are organized by the school, college, Institute within the campus of the institute, college, school.	<b>Extramural</b> competition are not organized by the school/ college/ institute/associations, amongst school/ institution/ college
<b>Intramural</b> competition is very easy to manage.	<b>Extramural</b> is tough to manage as compared to intramural.
<b>Intramural</b> no students of other school can participate in this activity.	<b>Extramural</b> competition the students of other school also participate in competition. It is also inter - school competition.
<b>Intramural</b> competitions large number of students are know each to other.	<b>Extramural</b> competitionmostof the students are not know to each other.

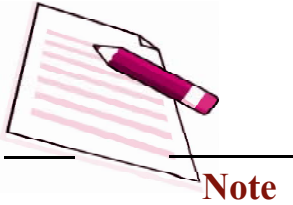


**INTEXT QUESTION 16.4**

1. Define intramurals.

.....





2. Define extramural.

.....

**Fill in the Blanks**

3. i) Inter-District tournament is type of .....
- ii) Inter class tournament is the type of .....
- iii) Intramural competition develops ..... quality.

**4. Match the statements of column 'A' with the statements of column 'B' in a meaningful way.**

- |  |  |
|--|--|
| 1) Intramural Competition  | A) Most of the students are not known to each other. |
| 2) Extramural Competition  | B) Very easy to conduct                              |
| 3) To encourage social interaction among the teams               | C) Intramural Competition                            |
| 4) Competition needs less time and funds to organize competition | D) Objective of Extramural Competition               |



**WHAT YOU HAVE LEARNT**

- There are four types of tournament like knockout tournament, league or round robin tournament, combination and challenge tournament.
- How to organize tournament and steps of organizing tournament.
- Intramural activity is organized in school between classes or houses
- Extramural activity is organized between different-different schools/ institution
- Fixture is a planned process of a tournament to be played
- Types of fixture, knockout, league or ladder and advantage or disadvantage of all types of fixture.



**TERMINAL QUESTIONS**

1. Make a knock –out fixture of 13 teams.
2. Make a league fixture of 12 teams.
3. What do you mean by tournament? Explain the importance and types of tournament.



4. What is intramural tournament? Describe how to conduct a sports event in a school.
5. Explain the various types of fixture and describe the duties of various committees in the sports event.



### ANSWER TO INTEXT QUESTION

#### 16.1

1. Tournament is a series of games or matches that are used to decide the winner of a competition.
2.
  - i) Knock out tournament
  - ii) League tournament,
  - iii) Challenge tournament,
  - iv) Combination Tournament.
3.
  - i) Tournament provides an opportunity to demonstrate games skill,
  - ii) Tournament motivate the people towards sports
- 4) In league or round robin tournament system a team has to play match with all the other participating team, hence the number of matches increase.

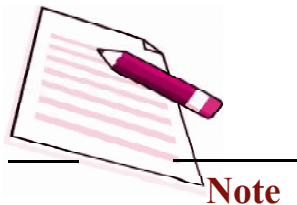
#### 16.2

1. Advantage of knockout fixture:-
  1. Less expensive
  2. Less time needed
  3. Less tiredness to players
  4. Less number of organizers required
- 2) Seeding: seeding is given to some special teams or players those teams/ players which were winner/ runner- up of the last year tournament.
- 3) Special Seeding: special seeding means the seeding players are brought straight away to quarter final.



#### Note





Note

### 16.3

1. Fill in the blanks
  - a. Challenge Tournament,
  - b. Combination Tournament,
  - c. League Tournament,
  - d. Knock-out Tournament.
  
2. Match the following –
  1. C
  2. D
  3. B
  4. A





17



373en17

## ATHLETIC INJURIES, FIRST AID AND SAFETY

Read a conversation between Ram and his PE Teacher, held at school sports field

Ram : Sir! When we get injured while playing, what are we suppose to do in emergency?

Sir : We should focus on First Aid which can be provided to the injured person.

Ram : What is First Aid? And how is it given to the injured?

This made the teacher to think about the need to provide knowledge about First Aid to the school students, so that they can help each other during emergency cases and also help themselves better. In this Lesson you will read about the Athletic injuries, concepts of First Aid, how to prevent injuries and also about safety measures at school, home, road and sports field.



### OBJECTIVES

After reading this lesson, you will be able to:

- classify the different types of injuries in sports;
- learn about the treatment of injuries;
- comprehend the principles of First Aid;
- apply preventive and safety measures to avoid injuries in sports field and outside and
- discuss the safety precautions.

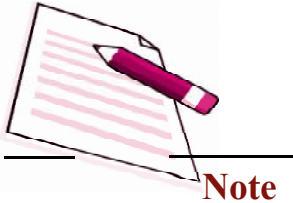


### 17.1 DIFFERENT TYPES OF SPORTS INJURIES

You all know that participating in physical activity, sports, exercise and recreational programs are enjoyable but they are also prone to injuries if not taken care of. We need to learn that injuries are unavoidable in sports, therefore, the focus must be on injury management and rehabilitation and care of the injured. You will enjoy learning about the occurrence of injuries and their management.




**Note**



Injury occurs when force exceeds the limit of tissue due to which there is damage to cells and blood vessels. Injury may occur due to any stretch or blow on the muscles leading to soft tissue injuries like strain or sprain. Damage to cell is called as cell necrosis due to which it cannot transport oxygen, nutrients and waste, leading to necrosis around the area of impact and further leading oedema. Blood vessel damage due to injury causes decrease in blood flow and coagulation (clotting).

### 17.1.1 Types of Injury

Its important to detail the different types or classification of injuries in sports on the basis of its nature and location.

#### Types of Injuries

Soft Tissue Injury	Bone Injury		Joint injury Dislocation
	Close Fracture	Open Fracture	
<ul style="list-style-type: none"> <li>• Contusion</li> <li>• Abrasion</li> <li>• Incision</li> <li>• Laceration</li> <li>• Strain</li> <li>• Sprain</li> </ul>	<ul style="list-style-type: none"> <li>• Transverse Fracture</li> <li>• Oblique Fracture</li> <li>• Spiral Fracture</li> <li>• Comminute Fracture</li> <li>• Impact Fracture</li> <li>• Green Stick Fracture</li> </ul>	<ul style="list-style-type: none"> <li>• Compound Fracture</li> </ul>	<ul style="list-style-type: none"> <li>• Subluxation</li> <li>• Luxation</li> </ul>

### 17.1.2 SOFT TISSUE INJURY

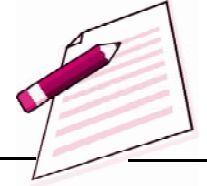
**Contusion:** Direct impact with blunt object which causes bleeding deep with muscles due to damage in capillaries. Wound look like bluish in color due to torn blood vessels



**Abrasion:** Loss of epidermis (Outer layer of the skin) superficial injury with loss of skin. Person feels burning sensation.



**Incision:** Cut on arteries, tendon, veins, nerves due to sharp objects



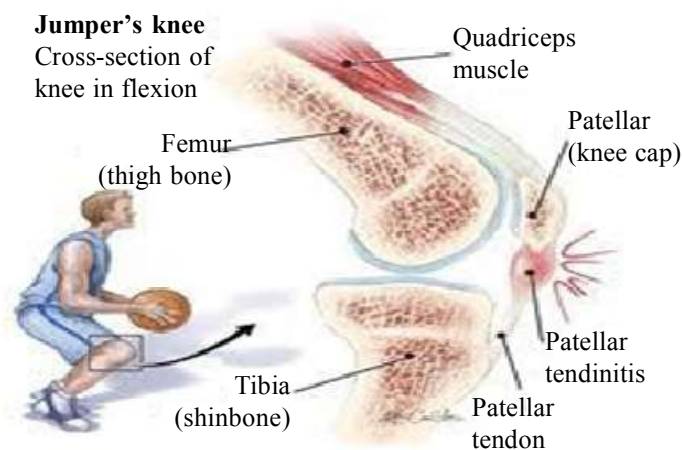
**Note**

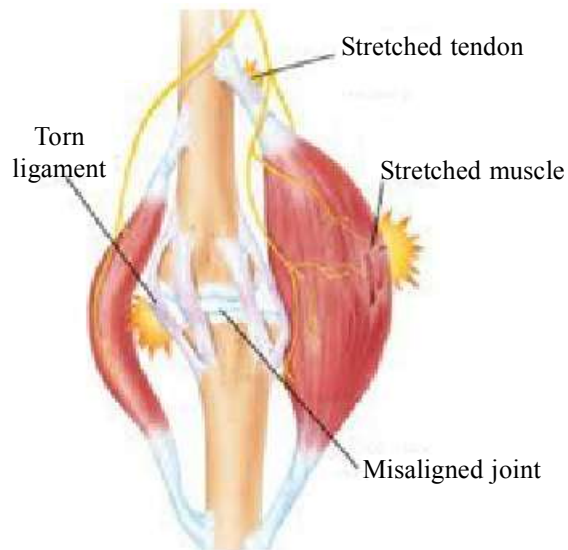
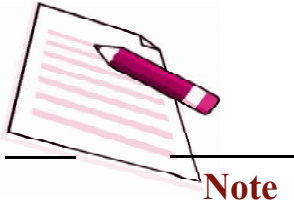
**Laceration :** Irregular tear in skin, cut in epidermis and dermis with blunt edge objects. An individual feel severe pain and redness beyond the wound edges.



**Strain :**Overstretching and tearing of muscle units is known as strain. Symptoms includes localized inflammation, severe pain etc.

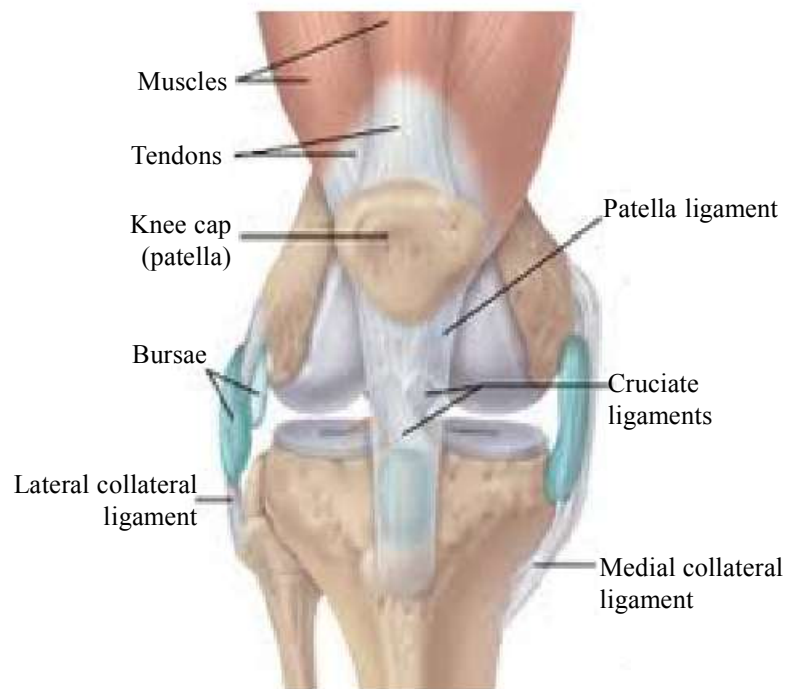
- i. Grade I: Mild – slightly pulled
- ii. Grade II: Moderate- Tear of fibre
- iii. Grade III: Sever – Rupture of muscle





**Sprain:**Overstretching and tearing of ligaments is known as sprain. Symptoms includes Pain, Tenderness, Loss of Function

- i. Grade I: Stretching or minor tear of one or more ligaments
- ii. Grade II: Partial tearing resulting in weakness or some loss of function
- iii. Grade III: Extensive tearing or complete rupture of ligaments generally require surgery.





**Note**

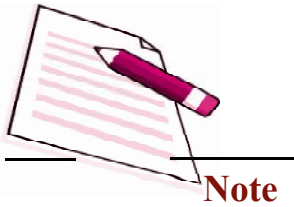
### 17.1.3 BONE INJURY

Fracture: It is a complete or incomplete break in a bone or discontinuation of bone resulting from the application of excessive force

- a. **Close Fracture:** A **closed fracture** is when the bone breaks but there is no puncture or open wound in the skin
  - i. **Transverse Fracture:** Broken at right angle to long axis of bone. *Transverse fractures of long bones* are usually the result of direct impacts, and thus are more common in older children after sports injuries.



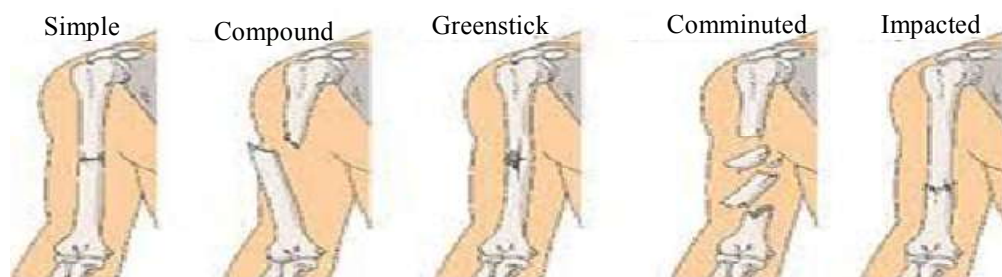




- ii. **Oblique Fracture:** A fracture in which the line of break runs in oblique direction to long axis confined to one plane. It is a slanted fracture of the shaft along the bone's long axis.
  - iii. **Spiral Fracture:** Occur when one end of an extremity is fixed (e.g., a foot is planted on the floor) but the rest of the extremity remains in motion.
  - iv. **Comminute Fracture:** A fracture in which the bone has broken or fragmented into several pieces. It happens mostly due to crush.
  - v. **Impact Fracture:** An impacted fracture is one whose ends are driven into each other. This is commonly seen in arm fractures in children and is sometimes known as a buckle fracture
  - vi. **Green Stick Fracture:** An incomplete fracture in which the bone is bent, it occurs most often in children in which the bone bends and partially breaks
- b. **Open Fracture:** An **open fracture** is one in which the bone breaks through the skin.
- i. **Compound Fracture:** is an injury that occurs when there is a break in the skin around a broken bone. In order for an injury to be classified as a compound fracture, the outside air (and dirt and bacteria) must be able to get to the fracture site without a barrier of skin or soft-tissue. Therefore, a bone does not need to be through the skin in order for the injury to be called a compound fracture.

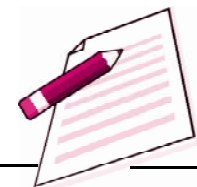


**Types of Fractures**



### 17.1.4 JOINT INJURY

- a. Dislocation:** When bones shifted their place from normal position, do not meet properly at the joint is known as dislocation. It can be divided into two types :
- Subluxation: There is partial dislocation in joints where slight displacement of bones takes place.
  - Luxation: There is complete dislocation where bones completely separate from each other



#### Note

## 17.2 TREATMENT FOR SIMPLE SPORT INJURIES

There are four steps to be taken care of common sports injuries. The process is known as R I C E which consists of four steps. This process should be started as soon as an injury occurs. In RICE, R stands for REST, I stands for ICE, C stands for COMPRESSION, and E stands for ELEVATION.

### Rest

An individual should immediately stop the activity as soon as an injury occurs. Delay may further damage the injured part. Rest must be taken until injured part gets fully recovered.

### Ice

Ice or cold water should be put on to the injured part as soon as possible to control swelling. It will help to decrease muscle spasm and also decrease pain. Cold water or ice should be applied for 20-30 minutes after a gap of 2-3 hours till 48-72 hours.

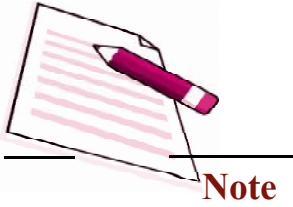
### Compression

Compression helps to limit and decrease swelling in the injured area. It should be applied with cold treatment. Compression can be done through elastic wrap of tape or belt but should not be too tight to stop circulation, or too loose to allow further swelling.

### Elevation

Last step of the process is to elevate the injured part. During the process support should be placed under the entire limb. The height should be enough that is high above from the heart.





The process of RICE should be continued for at least 48-72 hours. Any form of heat should not be applied under any circumstances, during this time otherwise it will lead to swelling and inflammation. In the process of optimal healing proper nutrition, good amount of sleep and a positive attitude is required.



**DO YOU KNOW?**

**Cartilages:** fibrous connective tissue placed over ends of the bones that allow smooth movement, absorb impacts. Any tear or break of cartilages is cartilages injuries.

**Bursae:** they are small sacs of fluid within joint to reduce friction. Bursitis occurs due to infection or overuse.

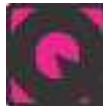
**Ligaments:** connective tissues that connect one bone to another bone is known as ligaments. Any tear or stretch of ligament known as sprain.

**Tendons:** connective tissues that connect muscle to bone known as tendons. Rupture or strained on tendons known as tendonitis.



**ACTIVITY 17.1**

Make a list of common injuries occurring in your favourite sport.



**INTEXT QUESTION 17.1**

1. Muscular tendon injury is known as  
.....  
.....
2. Injury to ligament is called as  
.....  
.....
3. Discontinuation of the bone due to impact, causing breakage of bone is called as?  
.....  
.....
4. Damage to cell causing death is called as  
.....





.....  
5. Outer layer of skin is known as  
.....  
.....

### 17.3 FIRST AID

It is the immediate assistance given to the person suffering from sudden injury or illness. The objective of first aid is to provide immediate care to the injured or ill person to preserve life and protect casualty from further harm before he reach to competent and qualified medical person or medical institution. First aid must be given by the first aider only, otherwise results may be adverse.

#### ***First aid box***

It is a handy box which contains following items by the first aider:

- Bandages
- Antiseptics
- Cotton balls and swabs
- Saline
- Hydrogen peroxide
- Iodine
- Dressings
- Eye wash
- Disposable gloves
- Scissors
- Adhesive Bandages
- Thermometer



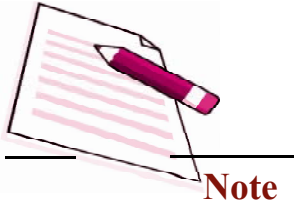
#### ACTIVITY 17.2

Prepare a First Aid Box with essential items required and stick a list of items along with its expiry date on the top of the box.



#### Note





### 17.3.1 Principles of First Aid

Read aloud the following principles of first aid :-

#### *Immediate action*

First step is to form the action plan immediately, first aider must be quick, quiet and without panic.

#### *Calling for medical assistance*

First aider should inform nearest medical unit with fastest possible means of communication. Patient can be transferred to the ambulance and can come off the place of injury or illness.

#### *Medical alert devices*

Individual having prolonged disease sometime take alert devices in which their history of disease or injury including specialist medical contact is mentioned.

#### *Reassurance and mental health*

Psychological values of reassurance are equal as treatment. Some individual go into shock and make situation more worsen. First aider should reassure them in order to reduce tension.

#### *Your response to an emergency*

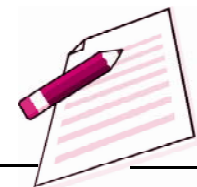
There are different types of emergencies in which individuals react differently. Sometime their response of disaster or injury may result in crying, fear, anxiety etc. it may last for weeks. By talking positive approach it can help to cope with injury.

#### **Common causes of injuries**

There are number of common risk factors that can lead to Athletic injuries.

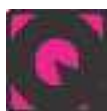
1. Lack of Warming up and Cooling down.
2. Overtraining or Excessive loading on the body
3. Non safety precautions
4. An accident
5. Inappropriate equipment





**Note**

6. Poor exercise techniques
7. Muscle weakness or imbalance
8. Joint laxity
9. Incomplete Calcification
10. Aging



**INTEXT QUESTION 17.2**

1. Mark the following as True/False.
  - a. First aid must be given by the trained first aider only
  - b. PRICE is not important in sports injury recovery
  - c. Warming-Up is not a reason for injury during sports participation
  - d. It is essential to be hydrated to prevent injury
  - f. Safety equipment are essential in sports to prevent injury.

**17.4 PREVENTION OF SPORTS INJURY**

***Basic physical fitness***

General fitness is important before indulging in any kind of activity. Bones and muscles must be strong enough to perform the activity effectively without having fatigue.

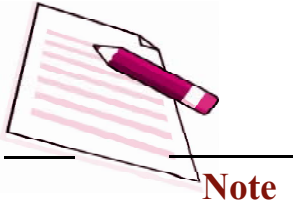
***Equipment***

The equipment must be carefully chosen to meet the demand of sport. The safety and technical equipment must be double checked in terms of quality before use. Comfortable and appropriate equipment is the prerequisite for any leisure and performance oriented activity.

***Health***

If somebody has suffered from infection or cold or other kind of disease, then he should not be involve in any physical activity. After suffering from disease, the body becomes weak the response from body goes slow, the chances of injury increase.





**Warming up and cooling down**

Before any type of physical activity an individual must do warming up with a purpose to increase temperature, mobility of muscles and mental preparedness. After activity, cooling down must be done to lowering down the temperature of the body and further stretch the muscles to prevent injuries.

**Systematic and scientific training**

Systematic and scientific training is important to bring effective training results. Training schedule should be prepared by the competent person. Unscientific training leads to injuries.

**Safety measures**

All the protective gears must be carefully checked. Surface of playing area, equipment, first aid, rule and regulations should be strictly followed.

**Psychological considerations**

Before and after activity psychological training is required. Mental readiness, alertness, confidence, make up of mind, memory etc. are the factors to be addressed before training to reduce injuries.



**INTEXT QUESTIONS 17.3**

Match the following

- |                          |                      |
|--------------------------|----------------------|
| <b>A</b>                 | <b>B</b>             |
| 1. P in PRICE stands for | i. Thermotherapy     |
| 2. Wax Bath              | ii. Prevention       |
| 3. Ice Pack              | iii. Cryotherapy     |
| 4. E in PRICE stands for | iv. Safety Equipment |
| 5. Helmet                | v. Elevation         |

**17.5 SAFETY PRECAUTIONS**

**School Safety:** “School Safety” has been defined as creating safe environment for children, starting from their homes to their schools and back. This includes safety from any kind of abuse, violence, psycho-social issue, disaster: natural and manmade, fire, transportation (NCPCR, 2017)



### School Sports Injury Prevention:

1. **Know and abide by the rules of the sport.** Kids should also be instructed in how to use the sport's athletic equipment properly.
2. **Avoid playing when very tired or in pain.** Children should take a break immediately if in pain.
3. **Keep kids hydrated.** Make sure there is adequate water or other liquids to maintain proper hydration. Kids need to drink 8 ounces of fluid every 20 minutes, plus more after playing.
4. **Wear appropriate protective gear,** such as shin guards for soccer, a hard-shell helmet when facing a baseball or softball pitcher, a helmet and body padding for ice hockey. Make sure your child uses the proper protective gear for a particular sport. This may lessen the chances of being injured.
5. **Make sure the coach is certified.** Enrol your child in organized sports through schools, community clubs, and recreation areas where there may be adults who are certified coaches. Ask about the coach's background and training.
6. **Get a pre-season physical examination.** Kids should have a thorough exam from a physician before participating in sports, including a cardiovascular workup to make sure there are no pre-existing conditions.
7. **Insist on a team emergency plan.** What happens if a child is injured? Where's the first-aid kit? Who drives to the hospital? Make sure any injured child sees a doctor right away.



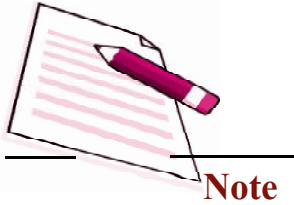
### Note



### DO YOU KNOW?

Supreme Courts Directive on School Safety Norms in India in a significant ruling, the Supreme Court ordered that no new government or private school would be given affiliation if the building did not have fire safety measures and earthquake resistant structure. Pained by the heart-rending death of 93 children in a fire at a Kumbakonam school in Tamil Nadu five years ago, a Bench comprising Justice H Dalveer Bhandari S Bedi said, "Children cannot be compelled to receive education from an unsound and unsafe building." Referring to painful incidents involving death of school children due to fire in Kumbakonam as well as Dabwali in Haryana in 1995, the Bench said,

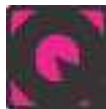




“It has become imperative that safety measures as prescribed by the National Building Code of India, 2005, be implemented by all government and private schools functioning in our country.” The other directions to all state governments are:

- All existing government and private schools shall install fire extinguishing equipment within a period of six months
- School buildings are to be kept free from inflammable and toxic material or stored safely
- Evaluation of structural aspect of the school building must be carried out periodically
- School staff must be well-trained to use the fire-extinguishing equipment

source: <http://indiankanoon.org/doc/232115>



### INTEXT QUESTIONS 17.4

1. Mark the following as True or False
  - a. Qualified and certified coaches are essential for safety of players ( )
  - b. Equipments should be tested regularly ( )
  - c. Medical report of student before physical exercise or sports participation is essential ( )
  - d. Over exertion of activity should be avoided during school sports activity ( )
  - e. Abide by rules of sports is essential for injury prevention ( )



### WHAT HAVE YOU LEARNT

- Injury occurs when force exceeds the limit of tissue due to which there is damage to cells and blood vessels.
- Injury may occur due to any stretch or blow on the muscles leading to soft tissue injuries like strain or sprain
- The objective of first aid is to provide immediate care to the injured or ill person to preserve life and protect casualty from further harm



- First aider should inform nearest medical unit with fastest possible means of communication. Patient can be transferred to the ambulance and can come off the place of injury or illness
- General fitness is important before indulging in any kind of activity.
- School Safety” has been defined as creating safe environment for children, starting from their homes to their schools and back.



**Note**



**TERMINAL QUESTIONS**

1. Describe sports injury and its classifications.
2. Explain the principles of FIRST AID.
3. Describe PRICE protocol.
4. How can we prevent sports injury among children?
5. Detail the points for Safety of children at school during sports.



**ANSWERS TO INTEXT QUESTIONS**

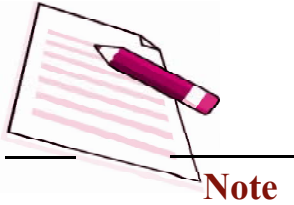
**17.1**

1. Strain
2. Sprain
3. Fracture
4. Cell Necrosis
5. Epidermis

**17.2**

- a. True
- b. False
- c. False
- d. True
- e. True





**17.3**

1. Prevention - (ii)
2. Thermotherapy - (i)
3. Cryotherapy - (iii)
4. Elevation - (v)
5. Safety Equipment - (iv)

**17.4**

- a. True
- b. True
- c. True
- d. False
- e. False





18



373en18

## HATHA YOG



### Note

Lord *Shiva* is considered to be the father of *Hathyog*. The successors of this tradition were *Sh. Matsyendranath*, *Swami Gorakshnath*, *Meennath*, *Bhartrihari* and further it was promoted by *Swatmaram* and other followers of 'Nath-Tradition' till *Sh. Gopichandra*. *Yog* practitioner becomes eligible for *Rajayog* through purified healthy body with the help of *Hathayog*. *Rajayog* is a practice of attaining *Samadhi* keeping pure consciences through *Yama-Niyama*. In this lesson you will learn about the Hatha Yog, its history and its benefits in our life.



### OBJECTIVES

After studying this lesson you will be able to:

- explain *Hathayog*;
- describe the Philosophy and History of Hatha Yog;
- identify the importance of Nadis and Chakras and
- explain the effects and benefits of *Hatha Yog*.



### 18.1 HATHA YOG

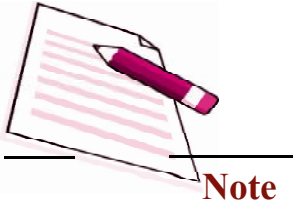
Hatha yog is a very important part of yog. It is a combination of two words Hatha and Yog. The literal meaning of Hatha is 'force' and is more traditionally defined as the 'yog of force or means of attaining a state of yog through force. But, here in Hatha yog 'Hatha' is meant quite differently. It is a combination of two beej mantras 'ha' and 'tha'. 'Ha' symbolically represents for 'sun' and 'Tha' for 'moon'.

*In Hatha yogic terms 'Ha' or 'Sun' or pingala nadi represents pran, the vital force and 'Tha' or moon or ida nadi represents mind, the mental energy. So, Hatha means the union of pran and mental forces.*

Yog is a Sanskrit word derived from 'Yuj' dhatu, which has thirty two meanings in Sanskrit dictionary. Here, Hatha yog means union, addition or integration etc. It is a state of bliss or the end of all human sorrows. So, the meaning of whole term 'hath yog' is the union of sun or pingla and moon or ida together.



## Yogic Practices



In hatha yog sun and moon are two fundamental part of our existence. So these two need more elaboration. Sun (pingla) means pran shakti, the life force and moon (ida) means manas shakti, the mental force. Every object in this universe, right from the smallest atom to the largest star is a combination of these two forces or energies. When they interact with each other, then creation begins to unfold. And when these two shaktis or energies are seperated from each other, creation is dissolved which is called ‘ pralaya’

In Hatha yog, there is the concept of harmonizing the above two fold energies in a human being. Normally, these two energies are in an unbalanced and unharamonized form in all of us. In some persons prana shakti or pingala is while in other ones, mental shakti is predominant and the pran shakti is subservient. Those whose pranic energy is predominant are prone to anger, quarrel, causing murder, committing crimes and violent behavior. Contrary to it, those whose mental energy is predominant are prone to mental imbalance like tension, depression, anxiety and stress etc. Hatha yog devise techniques to harmonize and create balance between these two energies which in turn not only gives, sound physical health, mental peace, emotional balance and above all evolution of human consciousness.



## INTEXT QUESTION 18.1

Fill in the Blanks -

- i) Hatha means the union of ..... and ..... forces.
- ii) Hatha yog devise techniques to .....and .....balance between these two energies.
- iii) Yog is a Sanskrit word derived from ..... dhatu, which has thirty two meanings in Sanskrit dictionary.

## 18.2 PHILOSOPHY OF HATHA YOG

As we have discussed earlier that the word Hatha is made up of two Sanskrit roots, ha and tha. Ha means ‘sun’ and Tha means ‘moon’. This is symbolic of the twin energy forces which exist in everything. Pran energy or vitality is dynamic and active. This is bodily energy or gross energy. The moon is the mental energy of chitta. It is the subtle force which is related with the mental layers. The two create the extremities of introversion and extroversion.

In the body there are specific path ways for channelizing these two forces. Just as in an electrical circuit you have suitable wires for the conduction of positive-negative electrical energy currents, similarly there are energy channels within



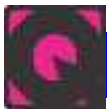
the structure of the body. These are known as nadis. Nad means flow. The mental energy travels along ida nadi which governs the left side of the body. pranic energy travels through pingla nadi and this governs the right side of the body. If these two separates flowing energies, prana and chitta are unified, it creates a suitable atmosphere for kundalini or spiritual energy, to awaken and ascend through the middle passage, sushumna nadi. This sushumna nadi represents the neutral force, the flow of spiritual energy.

The awakening of kundalini is the subject matter of Hatha Yog. It is believed in hatha yog that at the base of spine there is a chakra that is called mooladhar chakra. This chakra is a seat of primal energy that is also called kundalini shakti. But, this shakti is in sleeping mode here. This place is also called shakti meaning 'prakriti'. With the practice of Hatha Yog techniques, union is brought about. With this union, the kundalini shakti awakens and it starts ascending to higher realms of consciousness and finally it is established in sahasrara chakra at the crown of the head.

When kundalini ascends and gradually reaches at sahasrar chakra, shakti reaches to the place of Shiva Shakti unites with Shiva, at Sahasrar chakra. This is yog or union of Shakti with Shiva. Sahasrara Chakra is the place of Shiva. So, yog means union of Shiva (consciousness) and Shakti (energy). Shakti is kundalini energy, Shiva is the supreme consciousness seated in sahasrara chakra.

Kundalini ascends though sushumna, not through ida and pingla. Sushumna is the highway for kundalini . It passes through various chakras, sometimes all of a sudden and sometimes very slowly. When it unites with ida and pingala in ajna chakra, it is called hatha yog. Then after this first union it forges ahead to sahasasar chakra there it unites with the supreme consciousness, shiva. That is called yog, which means ultimate union. Therefore, the ultimate object of hatha yog is to experience yog. Swami Swatnaram aptly describes it in his book 'Hatha Yog Pradipika' that Hatha Yog is a ladder and Raj Yog is ultimate-  
pranamya shrigurumnatham swamiswaatmaramen yogina.

kevalam rajyogya hathvidyopdisyate 11(1/2 HP) means, first prostrating his guru, swamiswaatmaram instructs the knowledge of hatha yog only for raja yog the highest state of yog.



## INTEXT QUESTIONS 18.2

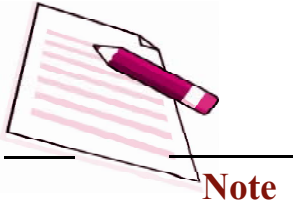
Mark as True or False-

- i) Ha means 'sun' and Tha means 'moon'. ( )
- ii) The moon is the physical energy of chitta. ( )
- iii) Sushumna nadi represents the neutral force, the flow of spiritual energy. ( )



### Note





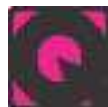
### 18.2.1 History of Hath Yog

Yog has been the part and parcel of Indian culture. It is so intermixed with the culture that we can not find its real origin in time. However, we have got its references in world's most ancient scripture Rig veda. The statue of a yogi sitting in lotus pose was found in the excavation of Indus valley civilization. Some historians believe that Indus valley civilization came before the Rig vada. But, one thing is certain that it is very ancient and dates back about 2000 BC. According to 'Yogi Yog walk' the founder of the yog is Hiranyagarbh. But there is no mention of sages or seers in this name in any yogic scripture or other Indian scriptures. Adi Sankaracharys says, "Hiranyagarbha is the symbolic name of Maharshi Kapil, the founder of " Sankhya Philosophy ". It is very clear that Mahanshi Patanjali was not the founder of yog as he himself has asked about this in the beginning of his treatisen 'yog sutra' .

Hatha yog is the product of tantra. There are few minor references of Hatha yog in ancient Upanishads and Puranas. But, it has got a lot of importance in Srimadabhagavatam. It has been mentioned several times in this book. Evidence of Hatha Yog has also been found in the pre- Columbian culture of the Americas. Even now , at St. Augustin, a southern province of Columbia in South America there are large stone figures and carvings depicting hatha yog practices.

There are many reliable texts on hatha yog- 'Hatha Yog Pradipika' written by Swami Swatnarma, Goraksha Samhita ' by Yogi Gorakhnath and Gheranda Samhita by great sage Gheranda. All these texts including all other major texts on Hatha Yog traditionally believe that its expounder was Lord Shiva also known as Adinath. It is believed that Lord Shiva gave this knowledge to Parvati. This knowledge came to Matsyendra Nath. Guru Gorakhnath the dutiful disciple of Matsyendra Nath was really the expounder of hatha yog and the founder of the Nath sect. It is also believed that Gorakhnath was probably the guru of Swami Swatmaram.

Guru Gorakhnath is regarded as the real founder of Hatha Yog. His birth time is not very clear but it is believed that this timing was in 9<sup>th</sup> century AD. All the texts are considered to have been written between 9<sup>th</sup> and 15<sup>th</sup> centuries AD. Its systematic form began to emerge in India sometime in the 9<sup>th</sup> century.



### INTEXT QUESTIONS 18.3

Mark as True or False-

- i. Hatha yog is the product of tantra. ( )
- ii. Hiranyagarbha is the symbolic name of Maharshi Kapil, the founder of " sankhya philosophy ". ( )



- iii. Hatha Yog Pradipika' written by Swami Swatmarma. ( )
- iv. Goraksha Samhita ' by great sage Gheranda. ( )

### 18.3 IMPORTANCE OF NADIS AND CHAKRAS

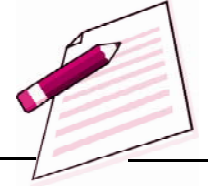
The word nadi is made of Nad which means flow or current. We generally take nerve and nadis as synonymous but actually nadis are the subtle channels through which the pranic forces flow. While nerves are gross in nature and manifest physical body. According to Hatha Yog Pradipik a there are seventy two thousand nadis in our psychic body. These are visible as currents of light to a person who has developed psychic vision.

But some hatha yog texts differ about the number of the nerves. Shiv Samhita says that there are three and half lakhs nadis in our psychic body. Out of the large number of nadis in our psychic body, ten are major. The most important of them are three nadis- ida, pingla and sushumna. All the nadis in our psychic body are subordinates of shushumna . That is why shushumna nadi is the most important among all.

Sushumna nadi is the spiritual channel. It is located in the centre of spinal cord. Its origin point is mooladhar chakra and end point is sahasrara chakra. Ida nadi symbolizes our mental body. It flows from the left side of mooladhara chakra in spine, passing through each chakra in turn, forming a criss- cross path way which terminates at the left side of ajna chakra.

On the other hand pingla nadi flow starts from the right side of mooladhar chakra, passing though each chakra just opposite to ida nadi and ends or terminate at the right side of the ajna chakra. While sushumna is just in the middle of these two opposite forces and terminates at sahasrara chakra. Ida which is passive introvert, feminine and cold in nature, is also known as Chandra or moon nadi. Pingala, on the other hand is active, extrovert, masculine and warm in nature is called surya or sun nadi. Thus, we can say that these two are just opposite forces flowing within us.

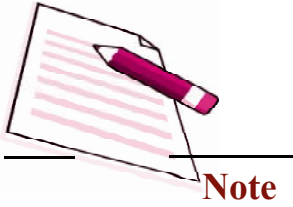
We can co-relate pranic flow with our breathing. If at any point of time current flowing is predominant from the left nostril, it shows that ida nadi is more active. When the flow is greater in the right nostril, then pingala is predominant. If the flow is equal then sushumna is predominant. If the right nostril flow is predominant, it means there is more vital energy for physical work, digestion of food, and activeness. It represents extrovert mind and body generates more heat. On the other hand, when the left nostril flow is predominant, mental energy is in excess. At this point of time mind is introvert and mental work is needed. During sleep ida nadi flows and gives deep sleep. But if pingla is predominant at night, sleep will be disturbed and restlessness will prevail. During intake of food, if ida



#### Note





*Yogic Practices*

nadi flow is more, then digestive process will be slow which in turn will cause indigestion.

All over activities are linked and influenced by the flow of these nadis. It changes approximately every sixty to ninety minutes. The flow of the nadis can be changed at our will. There are few yogic techniques which practice can change the flow of nadies voluntarily. For example, if ida nadi flow is more and we want to do some hard physical work, we can redirect the flow of the breath to pingla nadi to obtain necessary physical vital force and energy. Contrary to it, if at any point of time pingala flow is more, and one wants rest or sleep, then by the change of flow we can take rest and deep sleep.

The main objective of hatha yog is to bring about a balanced flow of prana in ida and pingala nadis. When both these nadis are purified and balanced and mind is controlled, then prana starts to flow in sushumna nadi, one of the most important nadis. When sushumna flows, kundalini awakens and rises through the chakras.

At the physical or body level, ida and pingala nadis correspond to our autonomic nervous system. Pingala coincides with the sympathetic nervous system and ida with parasympathetic nervous system. The sympathetic nervous system tends to stimulate and accelerate external activities. When this nervous system is more active our heart rate, breathing rate, dilation of the blood vessels, intensify the efficiency of eyes, ears and other sense organs. While parasympathetic nerves coincides with ida nadi and directly oppose above symptoms, which results in introversion. The flow of prana in ida and pingla is completely involuntary and unconscious until controlled by yogic practices

### 18.3.1 Chakras

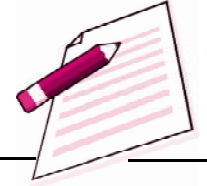
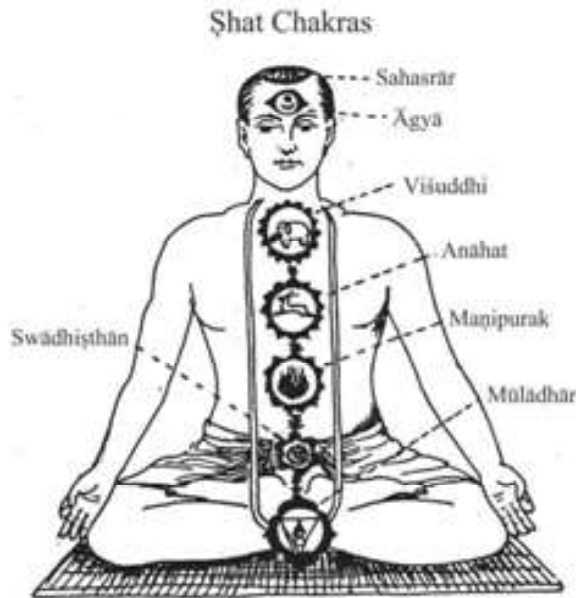
The literal meaning of word chakra is 'wheel' or circle, but in the yogic context a better translation is vortex or whirlpool. Each chakra is a switch which turns or opens up patterns of behavior, Thought or emotional reactions which may have been unconscious in our everyday life. They relate to specific areas of the brain and in most people these psychic centres, lie inactive and dormant. Concentration on the chakras stimulate the flow of energy which in turn activates subtle power.

There are seven chakras in our subtle body. They are located along the pathways of sushumna, which is also called bramharandhra. These chakras are infact located in the centre of the spinal cord. Sushumna orginates at the mooladhara or perineum and terminates at the top of the head- sahasrar chakra. These chakras are connected with nadis. The chakra are symbolically depicted as lotus flowers Each chakra have different number of petals and colours.

Lotus is the symbol of spiritual journey, which has three stages- ignorance, practice and illumination. It represents an aspirants level of spiritual growth



from lowest state of awareness to the highest state of awareness. The brief description of chakras is as follows-



### Note

### Mooladhar chakra

The word mool means root and adhar means base or place. Therefore, it is known as the root centre. This is the lowest chakra, which is situated at the perineum in the male body and the cervix in the female body. It manifests earth element or prithvi tattva. Its symbol is deep red lotus with four petals. It is believed that a red serpent, representing the dormant kundalini, is coiled three and half times around linga.

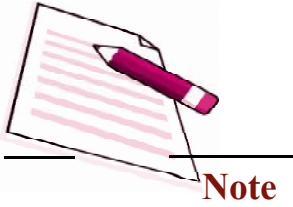
This chakra is the seat of primal energy, kundalini shakti. This kundalini shakti is the serpent coiled in deep slumber around linga. It is the source of all energy in human kind like- sexual, mental, emotional, psychic or spiritual. The aim of hatha yog is to awaken the dormant kundalini through purification and concentration of mind and lead it up to sahasrar chakra, where it unites with pure consciousness, Shiva.

### Swadhistan Chakra

The literal meaning of swadhistan is 'one's own place or abode'. It is situated just two fingers width above mooladhara chakra in spine. This chakra is symbolized by a crimson lotus with six petals. This is manifested by water element, apas tattva.

This chakra is associated with seeking pleasure and security. It is generally associated with tongue and genital organs. It manifests overwhelming desires or cravings. On a deeper level, it is the storehouse of our all subtle samsakars,





past mental impressions. In fact this is the animal consciousness level. By its purification the animal nature is transcended.

### Manipur Chakra

The word mani means gem and pur means city. Hence, Manipur means city of jewels. It is located in the spine just behind navel. It is a place of fire element. So it is a fire centre. This chakra is depicted as bright yellow lotus with ten petals. It is a place of vitality and energy. It is the centre of self assertion, dynamism, dominance, ambition and the will and ability to rule.

This chakra is mainly related to the vital process of digestion and food metabolism. It governs the functioning of gastric glands, the pancreas, gall bladder, which secrete enzymes, acids and juices necessary for the digestion and absorption of nutrients. A very important gland in our body adrenal is also associated with this chakra. This gland is responsible for secreting adrenaline into the blood during emergency. It speeds up all physiological processes making the mind sharp and alert.

### Anahata Chakra

The literal meaning of the word anahata is unstruck. All sounds in this world is produced by striking together of two objects which set up vibrations or sound waves. But, that sound which is not obtained by striking two objects together and which is beyond this material world, is called anahad nada. This chakra is located in the spine behind heart. This chakra is symbolized by a blue lotus with twelve petals. This is manifested by vayu tattava or air element. It is also linked with the sense of touch, emotions, ranging from the narrow attachment of jealousy to unconditional love. With the purification of this chakra the feeling of universal acceptance is achieved and patience and tolerance increases.

On the physical level, anahata is associated with the heart and lungs, and the circulatory and respiratory system. This is the symbol of jivatma.

### Vishuddhi Chakra

The word vishuddhi is a Sanskrit word. There is prefix 'vi' in the word shuddhi means purification. Vi is an adjective which means special. Therefore vishuddhi means specially pure. It is located in the spine behind neck. It is symbolized by a violet lotus with sixteen petals. It is linked with akash tattava, the ether element. Right understanding and discrimination develop at vishuddhi chakra. It is a place of wisdom, where person has the quality to accept the duality of up-down, profit loss and good bad.

At the physical level it is associated with ears, vocal cords, thyroid, larynx and parathyroid gland. This centre is the place where the divine nectar called amrita,





is tasted. Ajna chakra starts from new line- The word ajna means order or command. In deeper states of mediation the disciple receives commands and guidance from the guru, divine or higher self, this is why the name of this chakra is ajna. It is also named as third eye, jnana chakshu, triveni, guru chakra, eye of shiva and eye of wisdom. It is located in the mid brain, behind the eyebrow centre, at the top of the spine. This chakra is depicted as a silver lotus with two petals, which represent the sun and moon. Here two pranic flows which are responsible for the experience of duality, converge at this centre with sushumna, the spiritual force. The element of this chakra is the mind. This is the centre where wisdom and intuition develop. With the awakening of ajna chakra, mind becomes stable, steady and strong.

When ajna chakra is awakened telepathy and thought transmission power comes to the aspirant. It is like a psychic doorway opening into deeper and higher realms of awareness. With this it awakens intelligence, memory and concentration.

### Sahasrara

The very meaning of sahasrar is one thousand. Sahasrar is visualized as a shining louts of a thousand petals. It is situated at the crown of the head. it is a place of highest consciousness. At this chakra the mystical union of shiva and shakti take place, the fusion of consciousness with matter and energy, the individual soul with the' supreme soul. When kundalini awakens, it ascends through the chakras and finally reaches to sahasrara and here matter and energy merge into pure consciousness in a state of bliss. This is a place of supreme knowledge and moksha.

The main aim of Hatha hoga is to awaken kundalini and establish it in sahasrara chakra. Shakti is kundalini energy, Shiva is the supreme consciousness seated in sahasrar chakra. The union of shakti to shiva is the prime objective of Hatha Yog. To ascend energy from mooladhara to sahasrar, the supreme consciousness hatha yog has devised shatakarma, asan, pranayama , mudra, bandh and samadhi.

In order to purify mind, it is necessary to purify the body as a whole. Hatha Yog devised shatakarma technique at the very beginning. It is a combination of six purifying techniques. Swami Swatmaram depicts it as follows:

***‘Dhautirabastistatha netistratakam naulim tatha, kapalbhatishchaitani shatkarmani prachashhate.’*** (Hatha Yog Pradeepika - 2/22)

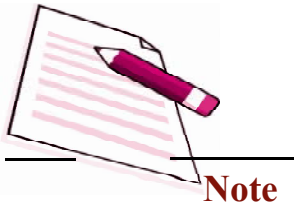
This means that there are six purifying techniques – Dhauti, Basti, Neti, Tratak, Nauli and Kapal Bhati.

Along with this asana, pranayam, bandh and mudra techniques are to be practised to reach the highest level of consciousness.



### Note

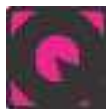




**Note**

### 18.4 EFFECTS AND BENEFITS OF HATHA YOG

1. It purifies the body to reach the higher realm of consciousness for this body purification is a must. Shatakarma practice helps to purify the body and which in turn helps to focus the mind. Purification also helps in increasing bodily immunity. The higher the immunity the lower of getting disease chance.
2. It is helpful in curing physical, mental, psychosomatic, emotional, spiritual problems. Even modern western medical science has accepted the need of yog in curing human diseases and other problems. It has given permanent cure to many problems like hypertension, heart problem, diabetes, asthma, anxiety, depression, stress and tension etc.
3. Yog is helpful in relaxing the mind and releases tension in the body. Day to day tension in our life affects our body negatively. Asan practice releases that bodily stress and thus saves the body from diseases.
4. It tones our nerves, muscles and visceral organs, which is very necessary to make our body and mind fit and healthy. It helps to keep spine flexible and supple.



#### INTEXT QUESTIONS 18.4

Fill in the blanks

- i. The word nadi is made of ..... which means flow or current.
- ii. Shiv samhita says that there are ..... and .....nadis in our psychic body.
- iii. The literal meaning of word chakra is.....or.....



#### WHAT YOU HAVE LEARNT

- ‘Hatha yog is a very important part of yog. It is a combination of two words Hatha and Yog.
- Hatha yog means union, addition or integration etc
- In hatha yog sun and moon are two fundamental parts of our existence



- In Hatha yog, there is the concept of harmonizing the above two fold energies in a human being.
- Hatha is made up of two Sanskrit roots, ha and tha. Ha means 'sun' and Tha means 'moon'.
- The awakening of kundalini is the subject matter of Hatha Yog.
- Yog had been the part and parcel of Indian culture.
- Hatha yog is the product of tantra.
- The word nadi is made of Nad which means flow or current
- Sushumna nadi is the spiritual channel. It is located in the centre of spinal cord.
- Each chakra is a switch which turns or opens up patterns of behavior, Thought or emotional reactions which may have been unconscious in our everyday life.
- Shatakarma practice helps to purify the body and which in turn helps to focus the mind.



### Note



### TERMINAL QUESTIONS

1. Describe the Physiology of Hatha Yog.
2. Explain the importance of Nadis.
3. List the benefits of Hatha Yog.
4. What is Chakra? Explain in brief.



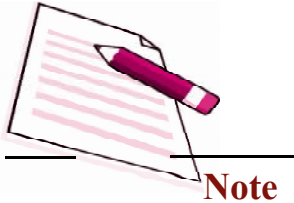
### ANSWERS TO INTEXT QUESTIONS

#### 18.1

- i. Pranic and mental
- ii. harmonize and create
- iii. 'Yuj'



*Yogic Practices*



**Note**

**18.2**

- i. True
- ii. False
- iii. True

**18.3**

- i. True
- ii. True
- iii. True
- iv. False

**18.4**

- i. Nad
- ii. three and half lakhs
- iii. 'wheel' or circle



19



373en19

## SHATKARMA

Read the conversation between Neha and her teacher-

**Neha** : Madam, we have learnt about yog in the previous lesson. May I also practise Yog?

**Teacher** : Sure, it is very necessary for all of us to practise yog to remain physically, mentally, emotionally and spiritually fit and healthy.

**Neha** : But I am very fat, I have sinusitis and acidity problem.

**Teacher** : Neha, you should start Shat Karma first to get rid of your physical problem. Then you should do other parts of Hath yog and yog.

**Neha** : Madam, what is Shat Karma. Please elaborate it properly.

Without proper cleansing, our mind and body will never be ready to receive maximum benefits from the yogic practices which are meant to propel the soul towards a higher sense of consciousness. Hence, *Shatkarma* practices are useful to purify subtle body through the cleansing of physical body. Let's now know about the Shat Karma i.e. meaning, types, precautions etc. in detail.



### OBJECTIVES

After studying this lesson you will be able to:

- explain the meaning of Shat karma;
- describe various components of Shat Karma;
- learn the Shat-Karma practices for detoxification and
- explain precautions and benefits of Shat Karma.



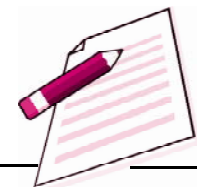
### 19.1 MEANING OF SHATKARMA

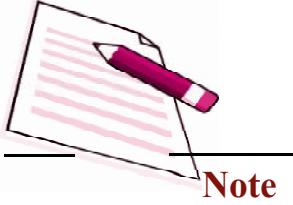
'**Shat**' is a Sanskrit word representing a numeric term as 'Six' and **Karma** means- 'action/procedure'. It means combination of six types of actions, which are done primarily for purification process and cleansing practices of specific bodily organs in yog.

*Physical Education and Yog*



**Note**





According to the Hath Yog and Ayurveda all our diseases occur due to the imbalance of tri-dosha i.e Vata (air element), Pitta (fire element) and Kapha (earth element). Hath Yog says that you need not take medicines to get rid of your diseases as these may have many side-effects. In order to avoid these medicines one can do Shat Karma as it balances all the five elements i.e. air, fire, earth, water and space of our body and make us physically fit which enables you to practise higher level of yog like Asana, Pranayam, Dharna and Dhyan etc. Shat-Karma creates harmony between the two major pranic flows- **Ida Nadi** (via left nostril) and **Pingala Nadi** (via right nostril). This way it helps in attaining physical cleaning and also keeps a balance between these two *Nadis*, which in turn helps to open the entry point of Sushumna Nadi- a gate way of Kundlini Shakti-the ultimate aim of Hath yog. But, remember one thing that it should be practised under guidance of expert.



### INTEXT QUESTIONS 19.1

- 1) Complete the sentence to make them meaningful.
  - a) Shatkarma procedure is mainly for .....
  - b) Cleansing practice of specific bodily organs is .....
  - c) According to ..... and Ayurveda all our diseases occur due to the imbalance of .....
  - d) In order to avoid medicines one can do ..... as it balances .....
  - e) Shatkarma creates harmony between the two major pranic flows ..... and .....

### 19.2 VARIOUS COMPONENTS OF SHAT KARMA

*Shatkarma* is a purification process of the body in the context of *Yog*. As we have studied above that there are six cleansing procedures in ShatKarma. They are:

धौतिर्बस्तिस्तथा नेतिस्त्राटकं नौलिकं तथा । कपालभांतिश्चैतानि षहट् कर्माणि प्रचक्षते ।।  
(हठ.2 / 22)

Shatkarma are as follows -

- 1) Dhauti
- 2) Basti



- 3) Neti
- 4) Trataka
- 5) Nauli
- 6) Kapalbharti

Above these six actions in Hath Yog are called purification practices.

### 1) DHAUTI

Dhauti karma is the first procedure described in ShatKarma. 'Dhauti' is a Sanskrit word which means- 'Washing or cleaning'. In Gherand a Samhita four types of Dhauti have been described, which are: AntarDhauti, DantaDhauti, HridDhauti, and Moolshodhan.

**Table No.2.1: Table Showing Types of Dhauti**

Antardhauti	Dantadhauti	Hriddhauti	Moolshodhan
Vaatsaar	Dantmool	Dand	-
Vaarisaar (Shankh prakshalana)	Jihvamool	Vaman(Kunjali)	-
Vahnisaar	Karnrandhra	Vastra	-
Vahishkrit	Kapalrandhra	-	-

In Hatha Yog Pardipika Vastra Dhauti and Gajkarni have been mentioned under the Dhauti Karma.

In terms of practice here we will discuss Vaman Dhauti (Kunjali) in detail.

### VAMAN DHAUTI (KUNJALI)

Vaman Dhauti is commonly known as Kunjal. This cleanses the mouth, food pipe and stomach. It is the most commonly practised procedure. This practice should be done in the early morning with empty stomach. In this Kriya drink saline (salt) lukewarm water until the feeling of vomiting starts.

#### Pre and Post preparation and Discipline:

- This kriya should be done after defecation (clearing the bowels).
- The kunjali Kriya is carried out in the early morning with empty stomach.
- Clean the hands and cut the nails before Kunjal.
- Keep the jug and glass near to you.
- Mix saindha namak (rock salt) into lukewarm water as told (procedure given below).

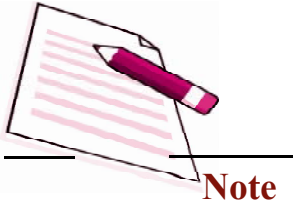


### Note





## Yogic Practices



- After Kunjal kriya one should eat Khichadi with ghee.
- Do not use chilly-spices on the day of completion of Kunjal Kriya.

**Method:**

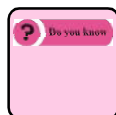
- 1) Sit in *Kagasana*.
- 2) Drink lukewarm saline water one by one glass continuously until the feeling of vomiting starts. That means when one cannot drink water anymore.
- 3) Then stand up and bend forward from the waist.
- 4) Then open the mouth and start rubbing root of the tongue by three fingers of the right hand.
- 5) At the beginning of the practice the water can come in small quantity but after repeat touching the root of the tongue, vomit starts. After long time practice, vomit starts without putting fingers at the root of the tongue.
- 6) This kriya should be done once a week.

**Benefits:**

- Kunjal Kriya is useful for maintaining the health of a healthy person.
- It is useful to clear the acidity of the stomach.
- Asthma patients also get relief from its practice.
- It removes the foul smell of the breath and the phlegm of the throat.

**Precautions:**

- Persons suffering from hypertension, stomach ulcers and cardiovascular diseases should not practice it.

**DO YOU KNOW?**

- How to prepare water for cleansing practice and what should be the temperature of lukewarm water?

Take boiled water or heat sterile water to that extent so that the water becomes lukewarm. To check the temperature of the water pour some water on the back of the palm. It should be bearable to the skin.

- How much salt is to be added to make saline water?

Add the sufficient quantity of rock salt to the lukewarm water so that the taste of water becomes similar to the taste of tears.





## ACTIVITY 19.1

See how kunjil is performed and try to do it your-self under the guidance of trainer.

### 2) BASTI KRIYA

Basti Kriya means the 'Enema' (cleansing of intestines through anal route). In the ancient times Yogis stand in the river or the pond at the level of navel and used to pull the water into the intestines through the anus and then used to remove the water from the anus again.

#### Modern Enema

It is a refined form of this ancient Basti Kriya. No one will be ready today to perform the Basti Kriya in the river. Therefore, instead of performing the Basti Kriya in the river, the 'Enema' apparatus are being used. Lemon-water or salt water is allowed to enter inside the intestines through an enema apparatus. If there are any obstructed faeces present in the colon they get released and the colon becomes clean. Person suffering from constipation gets benefit immediately by giving enema. Periodically taking an enema keeps body healthy.

The best time to perform this practice is early in the morning with empty stomach.

### 3) NETI KRIYA

Neti means cleaning of the nose and its surrounding area. It also improves eye sight and helps in treating disorders of nose. It is of two types:

- 1) Jal Neti
- 2) Sutra Neti

#### Jal Neti



Fig.19.1: Jal Neti

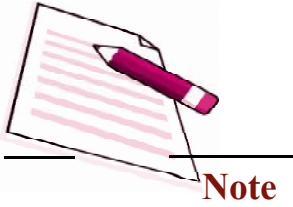


#### Note



373en28pm



**Method:**

- 1) Sit in *Kagasan*.
- 2) Take lukewarm saline water in the Neti pot.
- 3) Put the cone of Neti pot into the left nostril and keep the right nostril slightly downwards by tilting the head towards right.
- 4) During procedure take breath from the mouth by keeping the mouth open.
- 5) The water starts coming out from the right nostril. Also, phlegm/mucus comes out along with the water.
- 6) Do the similar procedure with the other nostril.
- 7) Immediately after Jal Neti the *Kapalbharti* should be performed so that the water remaining inside the nostrils also come out and the nostrils get fully opened.
- 8) After this, relax in *Shashankasan* for some time.

**Time-** Jal Neti is performed only in the morning with empty stomach.

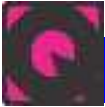
**Benefit-**It removes nasal tract problems for example- running nose, cough, sinusitis etc.

**Sutra Neti:**

**Fig.19.2: Sutra Neti**



In *Sutra Neti*, a waxed cotton thread is traditionally used to clean the nasal cavity. This waxed cotton thread is inserted into the nose and then pulled out from the mouth. Then both ends are held with the hands and nasal cleaning is done by to and fro motion of the thread. Nowadays, a rubber catheter is used instead of the thread and it is easily available in any medical store.



### INTEXT QUESTIONS 19.2

#### A) Fill in the blanks with appropriate word:

- 1) Six cleansing procedures of shatkarma are .....
- 2) First procedure described in shatkarma is.....
- 3) Kunjal is the common name for .....
- 4) Gherand Samhita described ..... types of dhauti.
- 5) Meaning of Basti is .....
- 6) Cleaning of nose and its surrounding area is known as .....
- 7) Immediately after Jal Neti ..... should be performed.

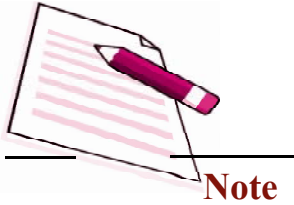
#### B. Mark the following sentence as 'True' or 'False':

- 1) Sadhak can sit in any asan for kunjal. ( )
- 2) Kunjal should be done once a week. ( )
- 3) Basti is the procedure where cleansing of intestine is done through anal route. ( )
- 4) During Jal Neti mouth should be closed. ( )
- 5) After Jal Neti relaxation is done in Shashankasan. ( )



#### Note





## 4) TRATAK KRIYA

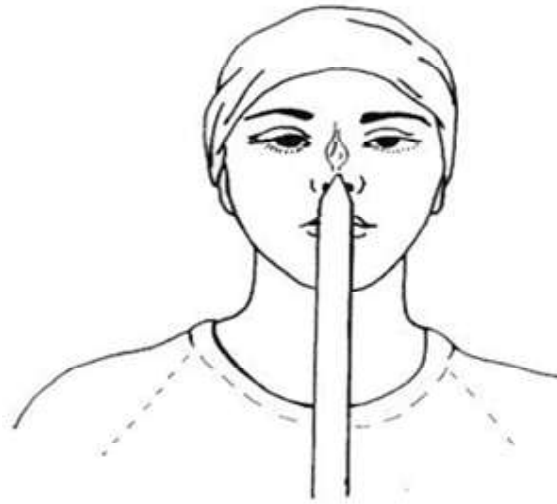


Fig.19.3: Tratak Kriya

Looking intently with blinkless gaze at a small point until tears are shed is known as Tratak Kriya.

Tratak is practised to activate unknown powers of the mind. Tratak is extremely powerful sadhna.

**Method:**

- 1) Light the *Ghee* lamp and keep it in front of the eye level at about 4 feet. Candle can also be taken in the absence of *Ghee*. The lamp should be placed in wind free area.
- 2) Sit in Padmasan or Sukhasan, keeping the back straight. Relax the whole body and be calm and quiet.
- 3) Now open your eyes and gaze at the flame of the lamp without blinking.
- 4) Gaze for as long as possible without strain.
- 5) When the eyes begin to tire, burn or shed tear then gently close your eyes.
- 6) Again open the eyes and start with the same procedure.
- 7) Slowly increase the practice. With practice, one can go from few seconds to few minutes without blinking. Do not extend it beyond 20 minutes.

**Time:** This kriya should be done regularly to get benefits.

This can also be done by drawing a black dot on the paper or on the symbol of “Aum”, instead of ghee, candle can be used.



**Benefit:** It helps in developing concentration. It strengthens the eye muscles.



## ACTIVITY 19.2

Practise Tratak regularly for 15 days and write your results/ experience.

### 5) NAULI KRIYA

It is the yogic exercise where the turning of the abdominal muscles take place.



**Fig.19.4: Nauli Kriya**

#### Method

- 1) Stand upright with two feet gap between legs.
- 2) Place both hands on the knees and lean slightly forward.
- 3) Look on the stomach and exhale completely to get in Uddiyan bandha.
- 4) Abdominal muscles will align and emerge out at the center of the abdomen. It shapes like a naal (tube/stalk).
- 5) Try to rotate emerged abdominal muscles from right to left and then left to right.
- 6) Placing these emerged abdominal muscles at the center of the abdomen is termed as “*Madhya Nauli*”, at the right side it is termed as “*Dakshin Nauli*” and at the left side it is termed as “*Vama Nauli*”.

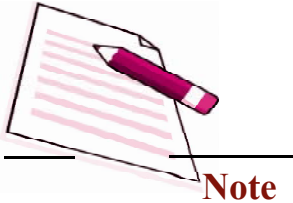


#### Note



373en30pm





**Note**



373en29pm

This kriya should be learned by all the Yogis.

**Time-** Its practice should be done in early morning, before meals and on empty stomach.

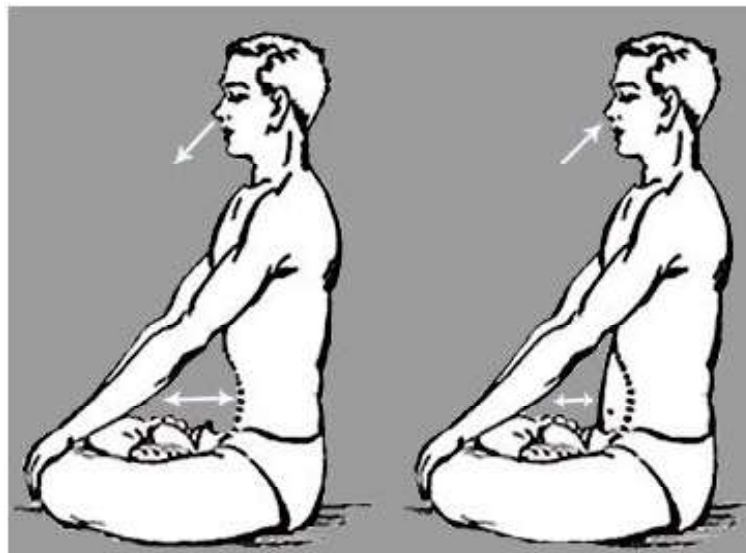
**Benefits-**

- It massages all the abdominal organs and keeps them healthy.
- It removes constipation and strengthens the digestive system.

**Note:** Patients suffering from hernia, ulcer, chronic renal and cardiovascular diseases should not practice it.

**6) KAPAL BHARTI**

The meaning of the ‘Kapal’ is ‘the brain’ and ‘Bhati’- to shine, i.e, kriya that cleans and shines the brain is called Kapalbhati.



**Fig.19.5: Kapal Bhati**

**Method**

- 1) Sit in Padmasan or Sukhasana with straight spine.
- 2) Keep both hands on the knees.
- 3) Take a deep breath normally by relaxing the abdominal muscles.
- 4) Exhalation should be rapid and forceful while the inhalation is normal.
- 5) Holding of breath is not done in Kapal bhati. Only exhalation and inhalation is practiced.
- 6) Exhalataion is the main part of Kapalbhati.





- 7) Repeat the same procedure about 20-25 times and gradually increase the time of practice.

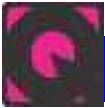
**Time:** practice can be done on empty stomach.

**Benefits:**

- It purifies the lungs and blood by increasing the amount of oxygen in the body.
- It calms down the mind.
- Regular practice helps in reducing the weight and detoxifies all the systems of the bodies.

**Precaution:**

- This is not suitable for heart and high blood pressure patients.
- Do not practice it in the summer for a long time.



### INTEXT QUESTIONS 19.3

**A) Fill in the Blanks with appropriate word:**

- 1) Looking intently with..... gaze at a small point until tears are shed is known as.....
- 2) Asanas for practising Tratak and Kapalbhathi are.....or.....
- 3) Tratak helps in developing.....
- 4) During Nauli kriya exhale completely to get in.....
- 5) Kriya that cleans and shines the brain is called.....
- 6) In Kapalbhathi exhalation should be.....and..... while the inhalation is .....
- 7) .....is the main part of Kapalbhathi.

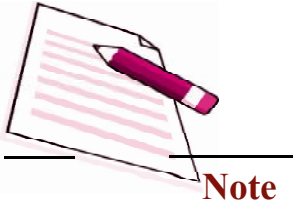
**B) Mark the following sentence as 'True ' or 'False'**

- 1) Tratak should be done regularly to get its benefit. ( )
- 2) Tratak strengthens eye muscles. ( )
- 3) Nauli kriya is done in sitting position. ( )
- 4) Patients suffering from hernia, ulcer, and chronic renal and cardiovascular diseases can do Nauli kriya. ( )



**Note**





- 5) While doing Tratak and Kapal Bhati no need to keep spine straight. ( )
- 6) Holding of breath is done in Kapal Bhati. ( )



### WHAT YOU HAVE LEARNT

- ‘Shatkarma’ (also known as Shat kriya) is a compound word consisting of ‘**Shat**’ and **Karma**. ‘**Shat**’ is a Sanskrit word representing a numeric term as ‘Six’ and **Karma** means-‘action/procedure’.
- *Shatkarma* is a purification process of the body. There are six cleansing procedures in ShatKarma namely-1. Dhauti 2. Basti 3. Neti 4. Tratak 5. Nauli 6. Kapalbhathi. These six actions in Hath Yog are called purification practices.
- Dhauti karma is the first procedure described in ShatKarma. There are many types of Dhauti but in terms of practice we have described Vaman Dhauti which is commonly known as Kunjal. This cleanses the mouth, food pipe and stomach. It is the most commonly practised procedure.
- Basti Kriya means the ‘Enema’ (cleansing of intestines through anal route). Now a days it is done by Basti apparatus with lemon or salt water.
- Neti means cleaning of the nasal passage and its surrounding area. It also increases eye sight and helps in treating disorders of nose. It is of two types- 1. Jal Neti- with lukewarm saline water. 2. Sutra Neti- with wax coated cotton thread.
- Tratak kriya- Looking intently with blinkless gaze at a small point until tears are shed is known as Tratak Kriya. It helps in developing concentration
- Nauli Kriya- the yogic exercise where the turning of the abdominal muscles take place. Placing these emerged abdominal muscles at the center of the abdomen is termed as “*Madhya Nauli*”, at the right side it is termed as “*Dakshin Nauli*” and at the left side it is termed as “*Vama Nauli*”.
- Kapal Bhati- kriya that cleans the brain is called Kapalbhathi. Exhalation is rapid and forceful while the inhalation is normal. Holding of breath is not done in Kapal Bhati. Only exhalation and inhalation are practised.





## TERMINAL QUESTIONS

- 1) What is meant by ShatKarma? Explain the procedure.
- 2) Write the types of Dhauti as described in various Samhitas.
- 3) Write Pre and post preparations and discipline of Vaman Dhauti.
- 4) Write any two benefits of Kunjal Kriya.
- 5) Write the benefits of Neti Kriya.
- 6) Write benefits and precautions of Kapal Bhati.
- 7) Describe first three procedures of Shat Karma in detail while explaining Shat Karma.
- 8) Describe last three procedures of Shat Karma in detail while explaining Shat Karma.



## ANSWERS TO INTEXT QUESTIONS

### 19.1

- 1) a) Purification
- b) Shat karma
- c) Hath Yog, Tridosha
- d) Shat karma, all five elements
- e) Ida and Pingala Nadi

### 19.2 (A)

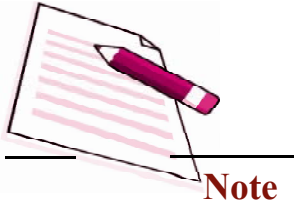
- 1) Dhauti, Basti, Neti, Tratak, Nauli and Kapal Bhati
- 2) Dhauti
- 3) Vaman Dhauti
- 4) Four
- 5) Enema
- 6) Neti
- 7) KapalBhati



### Note



*Yogic Practices*



**B) Mark True or False**

- 1) False
- 2) True
- 3) True
- 4) False
- 5) True

**19.3A**

- 1) Blinkless, Tratak
- 2) Padmasan, Sukhasan
- 3) Concentration
- 4) Uddiyan Bandh
- 5) Kapal Bhati
- 6) Rapid, Forceful, Normal
- 7) Exhalation

**B**

- 1) True
- 2) True
- 3) False
- 4) False
- 5) False
- 6) False



20



373en20

## ASANA



### Note

In the previous lessons, you have studied the spiritual component of physical education and Hatha Yog. We have discussed the effect and benefits of Hatha Yog also. It is clear that yog plays an important role in physical fitness, mental harmony, emotional balance, spiritual and moral values or overall personality development. 'Asana' is the third important ladder of Ashtanga Yog in the Patanjali Yogsutra. It is essential that we should perform the Yogic Sukshma Vyayama before practicing of Asana. Because Yogic Sukshma Vyayama prepares our body for practicing of Asana. It provides physical stability and firmness which makes the body strong and healthy. In this unit we will study about Yogasana and their different types, importance and need.



### OBJECTIVES

After studying this lesson you will be able to:

- explain the asana and its importance;
- describe the preparatory practices i.e. Sukshma Vayayam;
- explain the practice of Surya-namaskar and
- classify the asana.



### 20.1 ASANA

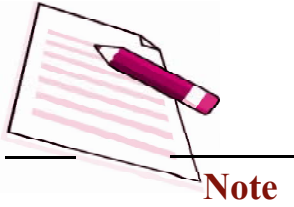
First of all we should know about the meaning of Asana. Asana means to sit. Asana is a stable and comfortable posture. The word Asana is generally used for a mat also. But in Yog, Asana is meant for posture which has a more important place in Yog Practices.

Maharshi Patanjali was a great seer who introduced and compiled Yog in a systematic way to the world. He has defined Asana in an easy way in his treatise 'Yogsutra':

**'Sthirasukhamasanam'** स्थिरसुखमासनम् (2/46 P.Y.S)



Yogic Practices



The meaning of this is ‘to remain steady with ease is Asana or posture. Here we should know that the meaning of Asana is a meditative pose like Sukhasana, Padmasana, Siddhasana etc. But in Hatha Yog Practices other form of postures are also considered as Asana.



Fig. 20.1



Fig. 20.2



Fig. 20.3

The purpose of an asana in Patanjali yog is to balance the different nerve impulses, feeling of pain and pleasure. Asana is an important part of hath yog. It is a specific body position which opens the energy channels and psychic centers.

In Hatha Yog, it is strongly believed that the practice of Asana gives control on our body and mind is, therefore, automatically controlled.

Here you should definitely understand that when one practices asana, steadiness develops and prana moves freely. When prana moves freely, the body also becomes supple and the toxins are removed from the system. The yogic scriptures say that altogether there are 84,00,000 of asanas, as many asanas as forms of life. We can also find a progressive evolution from the simplest form of life to the complex. But among 84,00,000 asanas, 84 are considered important and only 32 Asana are discussed in detail. These can be seen in *Gherand Sahinta*.

**Importance of Asana**

Asanas are very important for us in our life. They provide :

- physical stability
- firmness



- flexibility
- body tone
- sound health
- Peace of Mind
- Beyond duality



**Note**



**INTEXT QUESTIONS 20.1**

1. Define asana according to Patanjali.

.....

.....

.....

2. Explain the ultimate aim of asana according to hath yog.

.....

.....

.....

**20.2 PREPARATORY PRACTICES i.e. SUKSHMA VAYAYAM**

As it has already been told that Sukshma Vayayam is essential before practicing Asana. First we should perform the Yogic Sukshma Vyayama and then we should practice Asana. Here we should know the meaning of Sukshma Vayayam.

The word Sukshma means subtle and Vayayam means exercise. So those exercises which are mild, easy and have deep rooted effects are considered as Sukshma Vayayam.

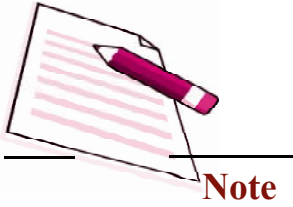
The concept of this practice is to provide all possible movements to every part of body joints in a comfortable, smooth and balanced way. It improves flexibility and prepares our body for intermediate group of asanas or classic asanas. Ideally all practices of this series are performed in a sitting position but we can modify it according to our requirement.

Sukshma Vayayam can be classified broadly in four categories:

i. Practice of Leg Joints





*Yogic Practices*

- ii. Practice of Hand Joints
- iii. Practice of Neck Joints
- iv. Practice of Eye

### 20.2.1 Preparations and Precautions before Yogic Practices

Now we will learn to practice these subtle actions in detail. But it is necessary to understand some instructions and precautions before doing the yogic practices and asanas. Carefully read and understand the instructions given below.

- The place of practice should be clean, open and airy.
- Practice always on carpet and bed sheet at flat ground.
- Use the comfortable and loose clothes according to the season.
- Practice should be done in easy and comfortable way according to capacity. Do not put undue stress & pressure.
- Glasses, watches and ornaments should be removed;
- keep your body relaxed while performing the action;
- When performing SV or asana, breathing should be taken only by the nose until mentioned otherwise;
- Before practising, Keep your stomach, intestine and bladder empty.
- Relax when you feel tired.

Now we will learn the practice. Read carefully the position and method of the Kriyas described below, understand and memorize and practise them at the right time.

### Prayer

Yogic prayer is considered necessary before starting any kind of yog practices.

### Position

- Stand erect, keep both feet together, body straight.
- Close your eyes.
- Join both hands together in front of chest, slightly above the heart area.

**Method:** Pray to God while meditating. For example the prayer should be done as follows –

Om.....

Asato ma sadgamyā;

Tamso ma jyotirgamyā;



Mrityorma amritamgamyā

Note - Instead, you can also make another prayer of your God according to your wishes.

## 20.2.2 Practice of Leg Joints

### Base Position

- Sit with the legs outstretched in front and palms on the floor beside the hip, fingers pointing backward or Dandasana.
- Head, neck and back should be in a straight line, and take support of the arms.
- Eyes closed and relax the whole body.
- Repeat the practice 10 times.

### Practice 1: Toe bending

- Sit on the Base position;
- Move the toes of both feet slowly backward and forward but ankles should be relaxed and motionless.
- Hold each position for a few seconds.

### Practice 2 – Ankle Bending

- Sit on the Base position;
- Slowly move both feet backward and forward, bend them from ankle joints;
- Hold the position for a few seconds.

### Practice 3 – Ankle rotation

- Sit on the Base position;
- Rotate both the feet clockwise and anticlockwise from ankle.

### Practice 4 – Butterfly

- Sit on the Base position;
- Bend the knees and bring the soles of the feet together;
- Keeping the heels as close to the body as possible ;
- Clasp the feet with both hands.
- Gently bounce the knees up and down;

Benefits –The practices are helpful in releasing hip joints, pelvic girdle and lumbar spine stress.



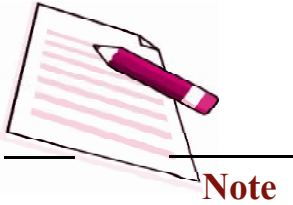
### Note



373en16pm



## Yogic Practices



373en17pm

### 20.2.3 Practice of Hand Joints

#### Practice – 1 Hand clenching

- Sit on the position of Dandasana;
- Stretch both arms in front of the body at shoulder level and palm facing downward;
- Open the hands, and stretch the fingers wide apart as possible ;
- Close the fingers and make a tight fist with thumb inside .

#### Practice – 2 Wrist bending

- Sit on the position of Dandasana;
- Stretch the arms in front of the body at shoulder level ;
- Keep the arms open and downward and fingers straight through out the entire practice ;
- Bend the palms from the wrist joint upward and backward.

#### Practice – 3 Wrist joint rotation

- Sit on the position of Dandasana;
- Make a fist with the both hands with the thumb inside;
- Slowly rotate the wrist joints clockwise and anticlockwise.

#### Practice – 4 Shoulder socket rotation

- Sit on the position of Dandasana;
- Place the fingers of the right hand on the right shoulder and left hand on the left shoulder;
- Fully rotate both elbows at the same time in a large circle clockwise and anticlockwise.
- Benefits –The practices are helpful in releasing shoulder stress.

### 20.2.4 Practice of Neck Movements

- Sit on the Base position;

Stage 1 : Move the head forward and Backward as much as possible comfortably .

Stage 2 : Move the head to the right and left side as much as possible comfortably .

Benefits –The practices are helpful in releasing neck and shoulder muscles stress.



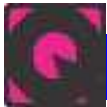
### 20.2.5 Practice of Eyes

#### Blinking-

- Sit on the Base position;
- Keep your eyes open ,
- blink the eyes 25 to 30 times quickly ;
- Close the eyes and relax it for 20 seconds.

#### Sideways viewing –

- Sit on the Base position;
- look at a fixed point in front;
- focus eyes on the extreme left for a few seconds;
- now focus eyes on the extreme right for a few seconds;



### INTEXT QUESTIONS 20.2

#### Fill in the Blanks with appropriate word.

- The word Sukshma means .....and Vayayam means exercise.
- Sukshma Vayayam can be classified broadly in ..... categories.

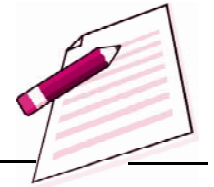
## 20.3 PRACTICE OF SURYA-NAMASKAR

We have learnt and practiced Sukshma Vayayam. Now we will discuss Surya-Namaskar. It is a wonderful practice for us to keep our body fit.

Surya Namaskara means salutation to the sun. It can be seen as a form of worship of the sun. In yogic terms this indicates that Surya Namaskara awakens the solar aspects of an individual's nature and releases this vital energy for the development of higher awareness. This can be realized by the practice of surya Namaskara . Surya namaskara is a series of twelve physical postures ,which has to be repeated by the other side then it makes one round . It is an effective way of loosening up ,stretching ,massaging and toning all the joints , muscles and internal organs of the body .

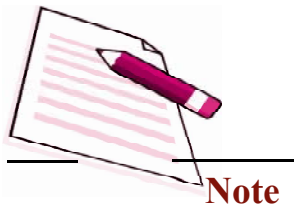


Fig. 20.4



#### Note





It is a set of 12 fixed yog asana, which is done in a certain order.

### 20.3.1 The method of Surya Namaskar

#### Preparation

- First stand erect with the feet together and the arms hanging loosely by the side of the body.
- Close the eyes gently and be aware of whole physical body.
- Take the awareness to the eyebrow centre and visualize the red rising sun infusing the whole body and mind with its vitalizing and healing rays.

#### First Position: Pranamasana (prayer pose )

- Slowly bend the elbows and place the palms together in front of the chest in Pranam-mudra.
- Relax the whole body and breath normally.
- Pray to God for sound health and wisdom.

#### Second Position : Hasta-Uttanasana

- Raise and stretch both arms above the head.
- Keep the arms separate shoulder width apart.
- Bend the head, arms, and upper trunk backward as much as is comfortable.
- Inhale while raising the arms and exhale while bending back.

#### Third Position: Padaahastasana

- Now, bend forward slowly and try to keep your palms on the floor besides the feet and forehead to the knees.
- But do not strain and keep the knees straight.
- Exhale while bending forward

Contra-indications –People with back problems, sciatica, slip-disk etc. should not do this pose. In these conditions forward bending is prohibited.

#### Fourth Position: Ashwa Sanchalanasana (Equestrian Pose)

- Now stretch the right leg back as far as possible and simultaneously bend the left knee as much as possible comfortably.
- Give a curve to the back and try to gaze upward . Make sure that right knee should be on the floor.
- Inhale while stretching the right leg back.



**Fifth Position: Parvatasana (Mountain pose )**

- Now take the left foot also back beside the right foot.
- Simultaneously, raise the buttocks up as much as possible and keep the head between the arms, so that the back and legs form two sides of a triangle.
- Try to keep the heels on the floor in the final pose and bring the head towards the knees, but do not strain.
- Exhale while taking the left leg back and keep breath normal in final position.

**Sixth Position: Asthanga Namaskara (Salute with eight parts of the body)**

- Now, Bend both knees and keep them on the floor.
- With this bend your elbows and keep your chest and chin on the floor.
- The part of the body between chest and knee - buttocks, hip and abdomen should not touch the floor.
- Take normal breathing.

**Seventh Position: Bhujangasana (Cobra Pose)**

- Now lower the buttocks and hips to the floor.
- Raise your upper body up and straighten your hands.
- Inhale while raising the torso and arching the back .

**Eighth Position: Parvatasana**

- This position is a repeat of position 5.
- Exhale while raising the hip.

**Ninth Position: Ashwa Sanchalana**

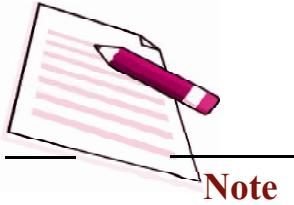
- Keep the palms flat on the floor and bring the right foot forward in between the hands.
- Place the left knee on the floor.
- Inhale while assuming the pose .

**Tenth Position: Padahastasana**

- This is a repeat of position 3.
- Bring the left foot forward next to the right foot.
- Exhale and straighten the knees.

**Note**

Yogic Practices



**Eleventh Position: Hasta uttanasana**

- This is a repeat of position 2.

**Twelfth Position Pranamasana (prayer pose )**

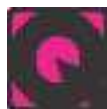
- This is a repeat position of 1.
- Exhale while assuming the final pose.

Note: Position 1-12 constitute half a round of Surya Namaskara. To complete the other half the same movements are performed with other leg in position 4th and 9th.

**20.3.2 Benefits of Surya-namaskar:**

Now we should know the benefits of Surya-namaskar.

- Surya-nmaskar is a complete set of exercises which provides complete health and body fitness.
- It strengthens and tones all parts of the body.
- It makes the spine and the waist flexible and removes the disorders.
- It keeps abdomen, intestine, stomach, pancreas, heart and lungs healthy.
- It helps to increase the blood circulation all over the body smoothly and removes the impurities of blood and destroys the skin diseases.
- It helps to balance secretion of hormones of all glands of the body.
- Surya-nmaskar enhances the vigour, vitality and mental peace.



**INTEXT QUESTIONS 20.3**

1. What is meant by Surya-namaskar?

.....  
 .....

2. How many positions are there in Surya-namaskar?

.....  
 .....

3. What is the seventh position of Surya-namaskar? Explain.

.....





## 20.4 CLASSIFICATION OF ASANAS

The Asanas may be classified in following categories mainly:

1. Meditative Asanas
2. Forward bending Asanas
3. Backward bending Asanas
4. Side Bending Asanas
5. Inverted Asanas
6. Twisting Asanas
7. Balancing Asanas
8. Relaxing Asanas

- **Meditative Asans:**

The aim of all Asanas are to make one capable of sitting in a meditative asans for longer period of time steadily with ease. There are three-four types of meditative Asanas like Sukhasana, Padmasana, Siddhasana, Swastik Asans etc.

- **Forward bending Asanas:**

There are many forward bending Asanas like Janushirasana, Pashchimottanasana, Padahastana, Yog mudra, Mandook Asana, Padprasara Pashchimottanasana etc.

- **Backward bending Asanas:**

There are many Backward bending Asanas like Ushtrasana, Sarpasana, Bhujangasana, Matsyasana, Chakrasana, Rajkapotasana, Dhanurasana etc.

- **Side bending Asanas**

There are many Side bending Asanas like Side bending, Tiryak Tadasana, Trikonasana etc.

- **Inverted Asanas**

There are many Inverted Asanas like Vipreetakarni Asana, Sarvangasana, Shirshasana, Vrishchikasana, Hand Stand Asana etc.

- **Twisting Asanas**

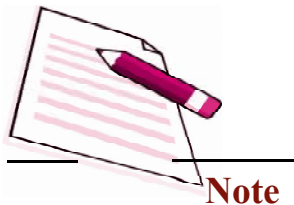
There are many Twisting Asanas like Meruvakrasana, Ardhamatsyendrasan, Vakrasana, Katichakrasana, Markatasana etc.



### Note



## Yogic Practices



Note

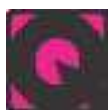
- Balancing Asanas

There are many Balancing Asanas like Tadasana, Vrikshasana, Ek padasana, Garunaasana, Bakasana, Mayurasana, Kukkutasana etc.

- Relaxing Asanas

There are many Relaxing Asanas like Shavasana, Balasana, Makarasana, etc.

We will study and practice all the above categories of Asana during the Practical Session.



## INTEXT QUESTIONS 20.4

Match the following in a meaningful way:

## A

- Titli Asana
- Astang Namaskar
- Dhanurasana
- Natrajasana
- Sarvangasana

## B

- Inverted asana
- Balancing
- Backward Bending asana
- Surya Namaskar
- Sukshma vyayama

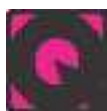


## WHAT HAVE YOU LEARNT

- Yog plays an important role in physical fitness, mental harmony, emotional balance, spiritual and moral values or overall personality development.
- 'Asana' is the third important ladder of Ashtanga Yog in the Patanjali Yogsutra.
- It is essential that we should perform the Yogic Sukshma Vyayama before practising of Asana. Because Yogic Sukshma Vyayama prepares our body for practising of Asana.
- Maharshi Patanjali has defined Asana in an easy way in his treatise 'Yogsutra' '*Sthirasukhamasanam*' स्थिरसुखमानसनम् (2/46 P.Y.S).
- The word Sukshma means subtle and Vayayam means exercise. So those exercises which are mild, easy and have deep rooted effects are considered as Sukshma Vayayam.



- Sukshma Vayayam can be classified broadly in four categories:
  - i. Practice of Leg Joints
  - ii. Practice of Hand Joints
  - iii. Practice of Neck Joints
  - iv. Practice of Eye
- Surya Namaskara means salutation to the sun. It can be seen as a form of worship of the sun. In yogic terms this indicates that Surya Namaskara awakens the solar aspects of an individual's nature and releases this vital energy for the development of higher awareness.



### TERMINAL QUESTIONS

1. Describe the Practice of Surya-namaskara with names of all positions and its benefits.
2. Write the techniques of hands joints S V and give its benefits.
3. What is meant by Asana? Classify them.
4. Write short notes on:
  - i) Eye practices ,
  - ii) Leg Joints Practices



### ANSWERS TO INTEXT QUESTIONS

#### 20.1

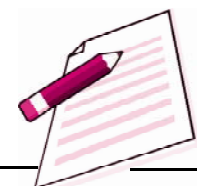
- 1) **‘Sthirasukhamasanam’** स्थिरसुखमानसनम्
- 2) In Hatha Yog, it is strongly believed that the practice of Asana gives control on our body and mind is therefore automatically controlled.

#### 20.2

- i) subtle
- ii) four

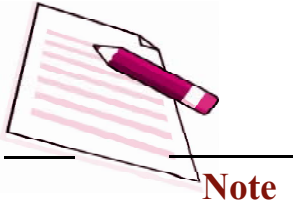
#### 20.3

- i) Surya Namaskara means salutation to the sun.



### Note



*Yogic Practices*

- ii) 12
- iii) Bhujangasana

**20.4**

- i) e
- ii) d
- iii) c
- iv) b
- v) a

**Suggested Reading and References**

- Maharishi Patanjali Yog Sutra,
- Hatha Yog Pradeepika - Swami Swatmaram,
- Yog And Kriya - Swami Satyanand Saraswati Y P T
- Asana Pranayan Mudra Bandha - Swami Satyanand Sraswati Yog Publication Trust, Munger, Bihar, India
- Shrimadabhadgavadagita
- Yogic Therapy By Swami Kuvalayananda Central Health Education Bureau Directorate General of health services, Kotla road, New Delhi

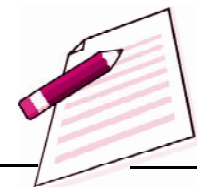


21



373en21

## PRANAYAM



### Note

So far, we have studied yam, niyam and asan described by Maharishi Patanjali in Yog Sutra. According to Ashtang yog, Pranayam is the fourth component. Here you must have to understand that after getting expertise in asanas one should start practice of Pranayam and this is described in all yogic scriptures. Ordinarily, every human being breathes from birth to death, unceasingly. But the question arises, how the breathing process of a common man is different from the one who is practising Pranayam? So first, we should be aware about the normal breathing pattern properly. Pranayam is the only connecting link between body and mind. Patanjali, in his text of yog Sutra, mentioned Pranayam as means of attaining higher states of awareness. The word ‘Pranayam’ implies control on pranas i.e., to attain control on breathing. In this lesson, we will learn about different types of breathing, how to control breathing, the types of Pranayam and how it affects our body, mind and soul.



### OBJECTIVES

After studying this lesson, you will be able to:

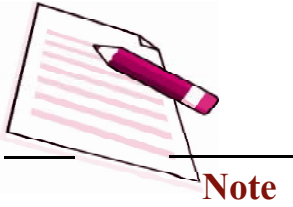
- explain the meaning of Pranayam and its importance;
- elaborate Pre- Pranayam practices;
- describe the components and types of Pranayam and
- explain the method of meditation through Pranayam.



### 21.1 PRANAYAM AND ITS IMPORTANCE

The word Pranayam has two Sanskrit roots - ‘Prana’ and ‘ayam’. “Prana” means vital energy and life force. “Ayam” means stretching, extension or expansion or control. Thus, we can say that the word Pranayam means extension or expansion of Prana or ‘breath control’ to extend and overcome one’s normal limitation of Prana. Therefore, it should not merely be considered as a breathing technique to provide extra oxygen into the lungs. It influences the flow of Prana in the Nadis of the Pranamay kosha. Controlling Prana through Pranayam steadies the mind and cleanses the body, thus it boosts the overall health and well-being of the





practitioner. Thus, the technique of Pranayam provides a method by which the life force can be activated and regulated in order to go beyond one's normal limitations and attain a higher state of experiences.

### Importance

Pranayam is one of the important vital components of yog that directly or indirectly affects the proper functioning of different systems of the body. Once you understand the right breathing technique, this can create a huge impact on your thoughts and actions. Pranayam practice provides people the freedom from any harmful and negative mental conditions such as depression, anger, arrogance, excessive greed for money and more. In addition, regular Pranayam helps extend life and enhance perception. By practising Pranayam, you can control mind's fluctuations and prepare yourself for deep meditation.

#### 21.1.1 Scriptural Reference about Pranayam

Pranayam is an important part of yog practices and is mentioned in almost all texts in yog. Maharishi Patanjali defines it as -

- **“Tasminsate swaspraswasiryorgativichchedah pranayam”**

*Pa. yo.su.2.49*

Which means, after getting expertise in asana there has to be regulation or restraint of speed of swas (inhalation) – praswas (exhalation) is called as Pranayam.

- **“Chale vate chale chittam, nischalam nischale bhavet**

**Yogisthanutyamapnoti tato vayum nirodhayet”**

*Ha. Yo.pra.2.2*

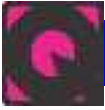
“When *Prana* fluctuates then the *Chitta* (mind) also fluctuates; when the *Prana* becomes steady then the *Chitta* also becomes steady”. So we should try to control *Prana*.

It means Pranayam practices are intended to bring about calmness in the mind by harmonizing the Pranic flow in the body.

We see warning in one *Shloka* in Hath Yog Pradipika (Ch 2.16). i.e., “Pranayam can remove all diseases if it is done correctly; if it is done incorrectly then it can actually cause illness”

This is the indication about Pranayam. It is a very advance practice, so one should slowly and systematically develop one's ability to perform Pranayam techniques over a period of time under the guidance of an expert.





## INTEXT QUESTIONS 21.1

- 1) Name the root words of Pranayam with their meaning.
- 2) Mark the following statements as 'True' or 'False'
  - a) Pranayam is considered as only a breathing technique to provide extra oxygen to the lungs. ( )
  - b) Pranayam is an important part of yog and is mentioned in almost all texts of yog. ( )
  - c) Pranayam can be practised even after not getting expertise in asanas. ( )



### Note

## 21.2 PRE-PRANAYAM PRACTICES

Let us know about Pre –Pranayam Practices:

The process of Pranayam is concerned with the breathing which is an indicator of life. So, if it is done in a wrong manner, it may harm us as we have just studied. Therefore, it needs some preparations. As we know that Pranayam is advanced yogic technique. A sound and healthy body is a must for the practice of Pranayam.

In the last topic, we have discussed about Prana, Pranayam and its impact on our life. Now we will learn about pre-Pranayam practices i.e. about the preparation technique of Pranayam practices. They are-

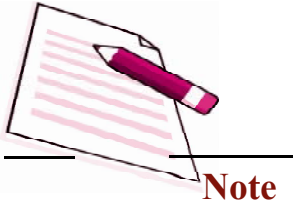
### 21.2.1 Asana

There are so many practices which are advisable for Pranayam and for the preparation of Pranayam. To successfully practise and attain the full benefits of breath control and pranayam, it is necessary that it be built on the solid foundation of a steady and comfortable sitting posture. The **spine should be straight** and perpendicular to the floor so that respiratory muscles can do deep breathing which is an essential requirement. Bad and poorly performed posture will lead to shallow breathing and low stamina. So, Asan is given utmost importance. So one should develop expertise in any one of the following Asanas-

- Siddhasan,
- Sukhasan
- Padmasan





**Precautions:**

- Always breathe through nostrils unless specifically instructed.
- Practise in quite clean and pleasant room which is well ventilated and free from dust.
- Wear light and loose comfortable clothes.
- Must empty bowel and bladder before practising.
- Food to be taken only 30 minutes after practising of Pranayam.
- Pranayam should be practised after practising asan and before meditation.

**21.2.2 Breathing Practice**

Breathing lies at the centre of human existence. Therefore, it forms core of any yogic practice. Breathing facilitates oxygen supply to the brain as well as to the rest of the body. Learning to properly control your breath will actually help you to attain a strong body and a sharp mind. Learning to properly breathe will help you get the most out of your practice and give an increased sense of vitality and energy and help in maintaining mental focus throughout the day. So, first let's learn about breathing:

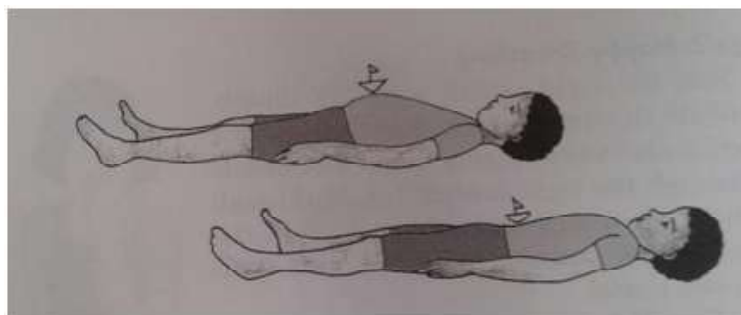
There are four types of breathing. They are -

**Natural/ Normal breathing**

Natural breathing is basically breath awareness. It is the starting point of working with the breath. It allows us to understand how we are breathing and our breathing patterns. It is relaxing, soothing and can be practised at any time. It is the basic starting point of meditation.

**Abdominal Breathing**

This type of breathing is associated with the movement of diaphragm and the outer wall of the abdomen. This form of breathing draws in the greatest amount of air at the least muscular effort. In this, during inhalation abdomen rises due to downward movement of diaphragm and on exhalation it falls down due to upward movement of diaphragm.



**Fig.21.1: Abdominal Breathing**



### Thoracic Breathing

In this form of breathing, chest and rib's movements take place. It expends more energy than abdominal breathing for the same quantity of air exchange. It is often associated with physical exercise and exertion, as well as stress and tension.

### Yogic Breathing

It combines all the above modes of breathing – abdominal and chest breathing into one harmonious movement. It is the ideal breathing that we are interested in developing. Only yogic breathing can give the maximum inhalation and exhalation. It may be practised at any time and is especially useful in stressful situations. Its purpose is to have a control over the breath, correct poor breathing habits and increase oxygen intakes. This is the best practice for gentle massage of abdominal and chest organs. This is a very useful practice to improve lung capacity.

**Note:** It can be practiced at any time. i.e., on empty stomach or after meals etc.



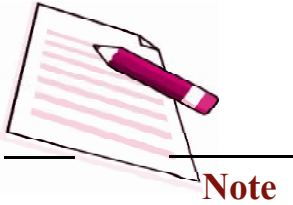
### INTEXT QUESTIONS 21.2

- 1) Name the Asanas required for Pranayam over which one should have expertise.
- 2) Name the four breathing types of pre-Pranayam breathing practices.
- 3) Fill in the blanks with appropriate asans:
  - i) Spine should be ..... for preparation of Pranayam.
  - ii) In thoracic breathing ..... and ..... movements take place.
  - iii) Yogic breathing combines all modes of breathing i.e ..... and ..... breathing in one harmonious movement.
- 4) Mark the following statements as 'True' or 'False'
  - i) Breathing can be done through mouth or nostril as per ease. ( )
  - ii) Abdominal breathing is associated with the movement of diaphragm and outer wall of the abdomen. ( )
  - iii) Yogic breathing can be practised at any time. ( )



### Note





### 21.3 COMPONENTS OF PRANAYAM

There are three components of Pranayam – Poorak, Rechak and Kumbhak. They are as follows-

- 1) **Poorak** or inhalation – It means complete inhaling (*swas*)
- 2) **Rechaka** or exhalation- It means complete exhaling (*praswas*)
- 3) **Kumbhak** – it means retention of breath. It is further divided into 2 parts.
  - i) Antar Kumbhak – Retention of breath after poorak
  - ii) Bahir Kumbhak – Retention of breath after rechak.
  - The most important component of Pranayam practice is Kumbhak or retention of breath.
  - Kumbhak should be practised under the supervision of expert.
  - Those who are suffering from high blood pressure, heart problems should not practise Kumbhak in their Pranayam practice.

#### 21.3.1 Different Types of Pranayam

In various yogic scriptures, we find different types of Pranayama (here Kumbhak) but the common types seen in all of them are Suryabhedhi, Ujjayi, Bhramri, Bhastrika, Sheetali and Sheetkari. Nadi shodhan/ anulom- vilom is performed before doing all these Pranayam.

For easy understanding, here they are categorized under following headings. They are -

- 1) Balancing Pranayam — Nadi Shodhan Pranayam
- 2) Tranquilizing Pranayam — Bhramri, Ujjayi
- 3) Cooling Pranayam — Sheetli, Sheetkari
- 4) Heating Pranayam – Bhastrika, Suryabhedhi

Now, we will study these in brief. The method of doing all these, we will learn in practical manual.

#### 21.3.2 Nadi Shodhan (Alternate Nostril Breathing)

Nadi shodhan literally means “channel clearing”. Though it is not a Pranayam yet it is considered as one of the basic types of Pranayam. The study of Pranayam must start with such basic procedure, so that it becomes easier to study and practise the different types of Pranayam. The Vayu cannot enter the Nadis if they are full of impurities. With this in mind, we study this Nadi Shodhan Pranayam first. It is a purifying Pranayam that alternates the blockage of each



nostril to channel air in a concentrated flow. It must be done before doing any pranayam.

Following steps instruct how to perform nadi shodhan:

- Sit down in any above mentioned Asan keeping spine erect.
- Now, use your right hand thumb to close the right side of your nose. Inhale slowly and deeply using the left nostril.
- Next, close the left nostril with fingers and exhale using the right one.
- In the same way, now with the left nostril still closed, inhale using the right nostril and exhale with the left one. This is one cycle.

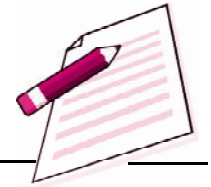
You can continue doing this practice for around 10-15 cycles.



**Fig.21.2: Nadi Shodhan or Alternate Nostril Breathing**

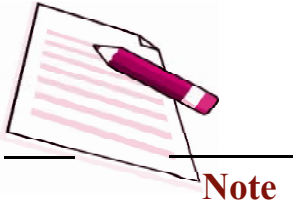
### Benefits:

- Though simple in practice, yet it is very helpful in making the respiratory system improve functionally. It strengthens all the respiratory organs which are quite helpful in further advancement of the practice of Pranayam.
- It is a basic practice with no limitation except retention of breath. Alternate nostril breathing is a safe practice.
- It ensures that the whole body is nourished by an extra supply of oxygen. The brain centers are functioning at their optimum level.
- It clears pranic blockages and balances the nadis including Ida and Pingla Nadis, which leads Sushumna Nadi to flow properly resulting in spiritual awakening. Hence, it is known as balancing Pranayam.
- It balances both the hemispheres of the brain. On the physical level, it balances nervous system. It develops inner awareness and sense of deep understanding.
- **Awareness** – On the alternate nostril breathing and eyebrow centre.



### Note



**Note**

### 21.3.3 Bhramari Pranayam – Humming Bee Breathing

In this type of Pranayam we exhale making a humming sound, the sound of ‘m’, as in the third letter of ‘aum’. It resembles the typical humming sound of bees. That’s why, it is called Bhramari Pranayam. Exhale slowly and do not strain. The sound should be smooth, even and controlled. It should be done under the guidance of expert.



**Fig.21.3: Bhramari Pranayam**

**Contra-indications:** Severe ear infection, ear ache, recent abdominal surgery.

If there is any feeling of faintness, dizziness, excessive perspiration or vomiting sensation, it should be stopped immediately.

**Benefits –**

- It is a tranquilizing Pranayama. So it is best suited for insomnia (sleeplessness) disorder.
- It relieves tension, anger and anxiety.
- It develops concentration and memory.
- It controls high blood pressure.
- It strengthens the throat and voice, useful for any throat problems.
- It is good for thyroid problems.

### 21.3.4 Sheetkari Pranayam

In Pranayam, we inhale through our mouth with the sound of ‘sheetkar’ which is produced on inhaling. Bring the teeth together lightly. Separate the lips so that teeth are exposed and then fold the tongue behind teeth to touch soft palate. Inhale slowly through the teeth. Close the mouth and exhale slowly through the nose. Keep the breaths slow and relaxed.



**Contra-indications:** People suffering from low blood pressure, respiratory disorder, excessive mucus, sensitive teeth, chronic constipation, hypothyroidism and hypoacidity should not practise this Pranayam. It should not be practised by the person having artificial teeth.

#### Benefits-

- This practice cools the body and mind.
- It induces muscular relaxations and mental tranquility.
- It helps to reduce blood pressure and acidity.
- It controls hunger or thirst, gives feeling of satisfaction.
- Helpful for nausea.
- It removes excessive heat, therefore, it is beneficial in summer.



Fig.21.4: Sheetkari Pranayam

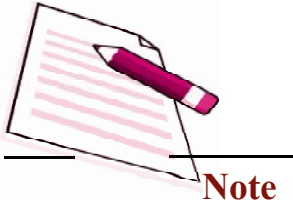
### 21.3.5 Sheetli Pranayama

As the name 'sheetal' suggests cool, calm and soothing; this Pranayam also helps us in achieving the same in practice. For this open the mouth and extend the tongue outside of the mouth, rolling it from the sides to form a tube. Inhale through the tube and exhale through the nose slowly and deeply.



#### Note



**Note****Fig.21.5: Sheetli Pranayam**

**Contra-indications:** -Same as Sheetkari Pranayam.

**Benefits:**

- It cools and reduces mental and emotional excitation. Other benefits are similar to Sheetkari Pranayam.

Both sheetli and sheetkari Pranayam are very useful in developing resistance against heat.

### 21.3.6 Ujjayi Pranayam (The Psychic/Victorious Breath)

Ujjayi means the ocean and this Pranayam is about mimicking the oceanic sound or the sound of the waves. In Ujjayi breathing, both inhalation and exhalation are through the nose. It is a diaphragmatic breath which fills the lower belly first, then the lower rib cage, the upper chest and throat. The opening between the vocal cords is contracted/ narrowed, creating a rushing or hissing sound. This audible breathing has been linked to ocean waves or snoring of a baby.

**Contra-indications** – People who are introvert by nature or suffering from fluid retention or low blood pressure should not practise this Pranayam.





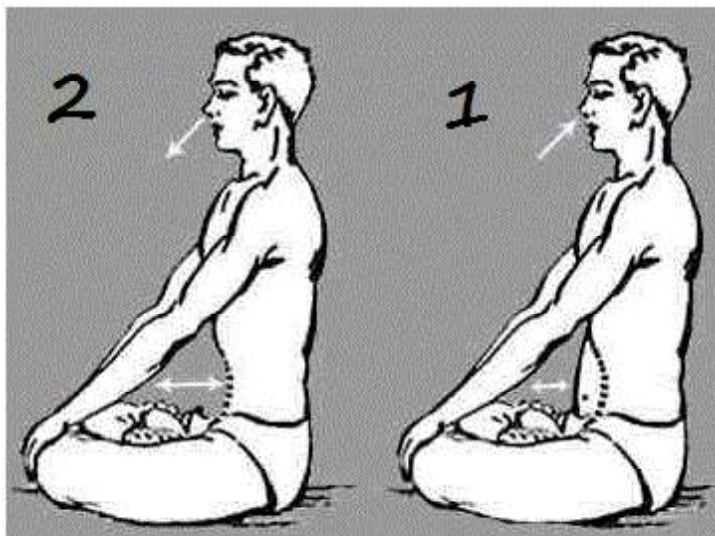
**Benefits:**

- It soothes the nervous system and calms the mind.
- It is beneficial in insomnia and hyperthyroid problems.
- It relieves mental tensions, stress, and anxiety.
- It has tranquilizing effect.

**Practice note:** The contraction of throat/ vocal cord should not be too strong. It should be gentle throughout the practice.

**21.3.7 Bhastrika Pranayam (Bellow's breath/ Heating Pranayam)**

'Bhastrika' is a sanskrit word which means 'bellows'. This Pranayam resembles the blowing of bellows, hence it is called Bhastrika Pranayam. It is an excellent breathing exercise which we can practise slowly or fast as per our convenience. Basically it is fast breathing. Take a deep breath through both nostrils and fill the lungs with air and then exhale with a hissing sound. Inhale deeply and exhale completely.

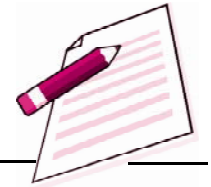


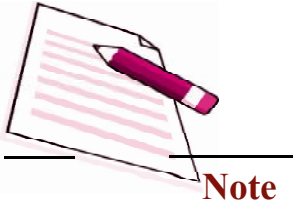
**Fig.21.6: Bhastrika Pranayam**

**Contra-indications**

High blood pressure, any heart problem, hernia, vertigo, hyper-acidity, ulcer, any recent abdominal surgery, or if there is too much heat in the body, stroke and hyperthyroidism.

**Practice note:** One should stop practice immediately if he/she feels - fainting, dizziness, excessive perspiration, excessive shaking of the body, vomiting etc.

**Note**



**Benefits –**

- Bhastrika purifies lungs, so it is very useful in asthma, tuberculosis and bronchitis.
- It corrects bad breathing habits.
- It speeds up the blood circulation.
- It optimizes digestive system by vigorous massage of the digestive organs.
- Increases the flow of prana throughout the whole pranic body.

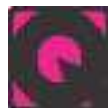
**21.3.8 Suryabhedhi Pranayam (Right Nostril Breathing)**

‘Surya’ means the sun and bheda means to pierce/awaken. In the body Pingala Nadi represents the energy of the sun or vital energy. Therefore, it means that we pierce or purify Pingala Nadi. In this Pranayam, we inhale and exhale through the right nostril.

**Contra-indications** - High blood pressure, heart disease, epilepsy, ulcer, acidity, hyperthyroidism, anxiety, headache or menstruation.

**Benefits-**

- Increases vital energy in the body.
- Heats the body.
- Stimulates the sympathetic nervous system and the left part of the brain.
- Eliminates Vata related trouble and
- Helps to balance Kapha.



**INTEXT QUESTIONS 21.3**

- 1) Fill in the blanks with appropriate words:
  - a) Three components of Pranayam are....., ..... and .....
  - b) The most important component of Pranayam practice is.....
  - c) Tranquilizing Pranayam are..... and .....
  - d) ..... is a purifying Pranayam.
  - e) Nadi shodhan strengthens all the ..... which are quite helpful in further advancement of Pranayam practice.
  - f) On.....humming sound is produced in.....Pranayam.
  - g) On .....sound of sheetkar is produced in .....Pranayam.
  - h) ..... Pranayam resembles the blowing of bellows.



- 2) Mark the following statements as 'True' or 'False'
- a) Sheetal Pranayam helps in cooling the body and mind. ( )
- b) In Ujjayi breathing, both inhalation and exhalation are through the nose. ( )
- c) People who are introvert by nature can do Ujjayi Pranayam. ( )
- d) In Surya bhedi Pranayam we inhale through the left nostril and exhale through the right nostril. ( )
- e) Just after abdominal surgery or hernia one should not practise Bhastrika Pranayam. ( )



### Note

## 21.4 HOW PRANAYAM PRACTICE LEADS TO MEDITATION AND SAMADHI?

In yogic meditation, breath training is essential preparation for deep meditation and Samadhi on the path to self-realization. When we try to meditate it is extremely common to have tension in the muscles and noisy thoughts in the mind. The nervous system is the mediator between the tense body and the noisy mind. One of the best ways to regulate that nervous system, and in turn the body and mind, is through the breath. Breath is the bridge between the body and the mind. Regulate breath, and the body and mind will follow. Patanjali in his text of yog Sutras mentioned the holding of breath as important practice in reaching up to Samadhi. So this is achieved through Pranayam practice. As we have studied pranayam is the way to control or regulate breath. With pranayam one can control or regulate pranic flow and achieve a healthy state of body and mind, and can attain higher states of awareness and self-realization.

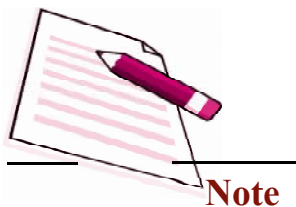


### WHAT YOU HAVE LEARNT

- The word Pranayam has two Sanskrit roots - 'Prana' and 'ayam'. "**Prana**" means vital energy and life force. "**Ayam**" means stretching, extension or expansion or control. Therefore, control of breath is Pranayam.
- Controlling Prana through Pranayam steadies the mind and cleanses the body
- **Pre- Pranayam Practices** are the processes of Pranayam concerned with the breathing. So, if it is done in a wrong manner, it may harm us. Therefore, some preparations are needed. They are- Asan and Breathing Practices.



## Yogic Practices



Note

- **Asan** - To successfully practise and attain the full benefits of Pranayam, it is necessary that it should be built on the solid foundation of a steady and comfortable Asan. Thus one should attain expertise in any one of these Asanas- Siddhasan, Sukhasan Padmasan.
- **Breathing Practice-** Breathing lies at the centre of human existence. Therefore, it forms core of any Yogic practice. There are four types of breathing- Natural, Abdominal, Thoracic and Yogic breathing.
- **Components of Pranayam-** There are three components of Pranayam – Poorak, Rechak and Kumbhak.
- There are different types of Pranayam told in yogic scripture and the common in all of them are Suryabhedhi, Ujjayi, Bhramri, Bhastrika, Sheetal and Sheetkari, Nadi shodhan/ anulom- vilom.
- Nadi shodhan literally means “channel clearing”. It is a basic and purifying Pranayam that alternates the blockage of each nostril to channel air in concentrated flow.
- Bhramari Pranayam- we exhale making a humming sound similar to humming sound of bees.
- Sheetkari Pranayam- In this we inhale through our mouth with the sound of ‘sheetkar’ which is produced on inhaling.
- Sheetal Pranayam- As the name ‘sheetal’ suggests cool, calm and soothing, this Pranayam also helps us to achieve the same in practice.
- Ujjayi Pranayam- This Pranayam is about mimicking the oceanic sound or the sound of the waves. Both inhalation and exhalation are through the nose.
- Bhastrika Pranayam- This Pranayam resembles the blowing of bellows, hence it is called Bhastrika Pranayam. Basically it is fast breathing,
- Suryabhedhi Pranayam- To pierce or purify Pingala Nadi is suryabhedhi Pranayam. In this Pranayam, we inhale and exhale through the right nostril.
- In yogic meditation, breath training is essential preparation for deep meditation and Samadhi on the path to self-realization. Breath is the bridge between the body and the mind. Regulate breath, the body and mind will follow accordingly. This is how Pranayam leads to meditation.



## TERMINAL QUESTIONS

- 1) Describe the role and importance of pre-Pranayam practices.
- 2) How breath, prana and mind are influenced by each other. Explain.





## ANSWERS TO INTEXT QUESTIONS

### 21.1

- 1) Pranayam has two root words - 'Prana' and 'ayama'. Prana means vital energy and life force. Ayama means stretching, restraining, extension or expansion.
- 2) a) Wrong  
b) True  
c) False

### 21.2

- 1) Sukhasan, Sidhasan, Padmasan
- 2) Natural breathing, Abdominal breathing, Thoracic breathing and Yogic breathing
- 3) i) Straight  
ii) Chest and ribs  
iii) Abdominal and thoracic
- 4) i) False  
ii) True  
iii) True

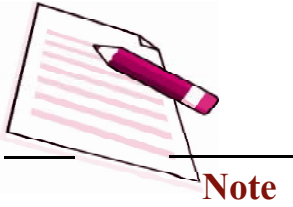
### 21.3

- 1) a) Poorak, Rechak and Kumbhak  
b) Kumbhak  
c) Bhramari and Ujjayi  
d) Nadi shodhan  
e) Respiratory organs  
f) Exhaling, bhramari  
g) Inhaling, sheetkari  
h) Bhastrika
- 2) a) True  
b) True



### Note



*Yogic Practices*

- c) False
- d) False
- e) True

**Suggested Reading and References**

- Asana Pranayan Mudra Bandha By Swami Styanand Sraswati Yog publication Trust, Munger, Bihar, India
- Prana Pranayam Prana Vidya By Swami Niranjanananda Sraswati Y P T
- yog And Kriya By Swami Styananda U Sraswati Y P T
- Experience Of yog World yog Convention Y P T
- Yogic Therapy By Swami Kuvalayananda Central Health education Bureau Directorate General of health services, Kotla road, New Delhi
- Raj yog by Swami Vivekananda – Shri Ram Krishna Vivekananda Sahitya publications.
- Hath yog Pradipika – Swami Satysananda Saraswati YPT
- [www.yogmag.net](http://www.yogmag.net)
- [www.biharyog.net](http://www.biharyog.net)



22



373en22

**Note**

## MUDRA AND BANDHA

In the previous lesson we have learnt about Pranayam and its benefits in detail. Now in this lesson we will learn about Mudra and bandha. Practice of Mudra and Bandha is considered to be more effective than practice of asan and Pranayam. So the persons, who cannot perform or are unable to perform asan and pranayam, can avail the benefits by practising Mudra and Bandha to maintain their health. In yog these are used to regulate pran energy i.e. vital force which you have studied in previous lesson.



### OBJECTIVES

After studying this lesson you will be able to:

- explain the meaning of Mudra and its importance;
- explain the methods of various types of Mudra and
- elaborate the meaning of Bandha and its importance.



### 22.1 MEANING OF MUDRA

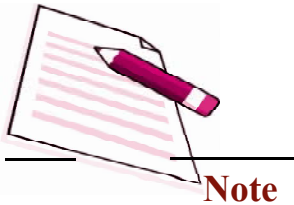
Mudra is a symbolic gesture used in yog. The Sanskrit meaning of the word **Mudra** is- 'gesture', 'mark' or 'seal'. In yog and meditation Mudras are most commonly known as hand positions, which are believed to affect the flow of energy in the body and chakras by clearing the psychic centers and energy channels.

There are various types of mudras and each type has a specific effect on the body and mind. Although hand mudras are most common in yog, there are also face, postural, lock and other mudras. The main texts concerning the use of mudras are the Hatha Yog Pradipika and Gheranda Samhita. The Hatha Yog Pradipika describes 10 Mudras whereas the Gheranda Samhita describes 25 Mudras.

*Physical Education and Yog*







### 22.1.1 Importance of Yog Mudra

Yog in general is considered to be a combination of postures (for stretching) and breathing techniques (for calming and relaxation). Postures (Asan) affect all the body systems while breathing practices (Pranayam) bring awareness of the relationship between the body and mind.

- 1) It helps in flow of prana in the body if it combines with yogic breathing exercises
- 2) It creates a connection with brain.
- 3) It makes change in the sensory organs, glands, veins and tendons.
- 4) The use of mudras adjusts the flow of energy affecting the balance of air, fire, water earth and ether for healing.
- 5) Mudra is a practice of physical, mental and spiritual well-being.



### INTEXT QUESTIONS 22.1

#### A) Fill in the blanks the appropriate words:

- 1) ..... is a symbolic gesture used in yog.
- 2) ..... Mudras are most common in yog.
- 3) Mudras described in the Hatha Yog Pradipika are ..... whereas in the Gheranda Samhita ..... Mudras.

## 22.2 TYPES OF MUDRA

### Hast Mudra

The well being of our health can be controlled by the fingers of our hand because the fingers are essentially electrical circuits. It can adjust the flow of energy. Touching the fingers of hand in different positions is known as Hast Mudra.

The Hast mudra can be used to balance five vital elements of the body through five fingers of the hand. Each finger represents each element. These are as follows:

- 1) Thumb – Agni/ fire element



Fig.22.1: Fingers Representing Elements



- 2) Index finger – Vayu/air element
- 3) Middle finger – Akash/ space element
- 4) Ring finger– prithvi/ earth element
- 5) Little finger – jal/ water element

Now we will study different types of Mudras-

### Gyan Mudra

It is the most popular mudra among hand mudras. It is used in all types of practices like meditation, worship, healing, dancing etc. The meaning of the Sanskrit word “Gyan” is Supreme Knowledge. Popularly known as the “mudra of knowledge,” The practice of this mudra enhances brain.



Fig.22.2: Gyan Mudra

### Method

- 1) Sit for meditation, relax your body and sit straight.
- 2) Put your hands both in front of your knees and join the tips of your thumb and index finger.
- 3) Touch the tip from skin to skin and not to the nail. Keep the other fingers straight and relaxed.

### Benefits

- 1) This Mudra stimulates the air element of our body and thus empowers mind.
- 2) It helps in increasing concentration and is the best remedy for dullness, inactiveness, and lack of enthusiasm, recklessness, lack of creativity and loss of memory problems.
- 3) People suffering from Alzheimer’s disease and other nervous system disorders will be benefited.
- 4) It helps in decrease of diseases such as Hypothyroidism, Hypoparathyroidism, Hypoadrenalism, and Hypopituitarism.

### Duration

Daily thirty minutes of practice is enough to get best results of Gyan mudra. You can do it at any place or anytime. To get quick results it is preferred in early morning with meditation posture.

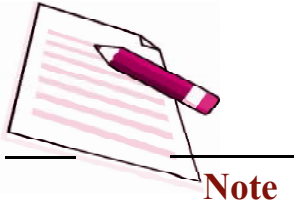
### Precautions:

- 1) Pregnant women should not practise it for long duration without the guidance of a yog teacher.



### Note





- 2) If a person is suffering from severe migraine or headaches it is best to practise with open eyes.

### Vayu Mudra

This mudra is also called as Vayu shaamak mudra because it is useful to decrease air element within the body.

#### Method

- 1) Press the tip of both index fingers into the root of thumbs.
- 2) Now fold your thumb inwards so that it presses the index finger lightly.
- 3) The other fingers should be held straight.
- 4) This can be done in any sitting pose, which are used while doing meditation.



Fig.22.3: Vayu Mudra

#### Benefits

- 1) It helps to balance the air inside the body.
- 2) It solves the problems such as flatulence and joint pain.
- 3) If one feels uneasy after a meal, it should be practised in the Vajra Asana (Diamond Pose).
- 4) It is helpful in reducing Parkinson's disease.
- 5) It helps in decreasing anxiety and restlessness.
- 6) It is effective in hormonal imbalances.

#### Duration

Daily practice of 30-45 minutes is enough to get best results. To get quick results it is preferred in early morning with meditation posture.

#### Precautions

- 1) After getting relief in pain one should release the mudra. It is not beneficial to continue for longer duration after getting relief in pain.

### Surya Mudra

It is one of the most famous Mudra in hand mudras. The practice of this mudra is useful in reducing earth element within the body.



Fig.22.4: Surya Mudra



**Method**

1. This can be performed in any pose used for doing meditation.
2. Place the tip of the ring finger on the base of the thumb.
3. Bring the gentle pressure of the thumb upon this finger.

**Benefits**

1. It reduces coldness of body.
2. Beneficial in inactivity of thyroid glands.
3. Beneficial in overweight and obesity.
4. Beneficial in loss of appetite.
5. Beneficial in digestion problems like constipation, indigestion etc.
6. Helpful in no sweating or less sweating of body.
7. Cure Vision or eye problems.

**Duration**

Regular practice of 30 minutes is enough to get maximum benefits. To get best results it is preferred in early morning and meditation posture.

**Precautions**

1. Don't do it in high blood pressure.

**Ling Mudra**

Linga mudra is the best mudra to improve fire element in the body.



Fig.22.5: Ling Mudra

**Method**

1. Sit in any meditative pose.
2. Now interlock both palms by keeping the left thumb erect, pointing upwards.

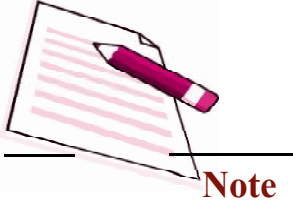
**Benefits**

1. It burns the extra fat in the body that helps in weight loss.
2. This mudra increases hotness in the body that helps to relieve cold and related ailments such as sinusitis, wet cough and sticky stools.
3. Beneficial in asthma and other respiratory disorders.

**Duration**

Regular practice of 30 minutes is enough to get desirable results. This mudra should be practised only when there is a need.

**Note**

**Note****Precautions**

1. Don't do in fever or having pitta Prakriti.
2. Don't do it for long duration as it will affect organs.

**Prithvi Mudra**

Sanskrit term, Prithvi means “the vast one” and is also the name of Earth.

This mudra is useful to increase earth element and decrease fire element in body.

**Fig.22.6: Prithvi Mudra****Method**

1. Sit in any meditative pose.
2. Touch the tips of the ring finger and the thumb with slight pressure.

**Benefits**

1. It increases strength and endurance of the body.
2. In a lean and thin person, this mudra is highly beneficial for overall health.
3. It gives relief from ulcers and burning sensations.
4. Beneficial in jaundice and fever.

**Duration**

Regular practice of 30-45 minutes is enough to get good results. You can do it anytime or in any place but the morning hour or when you are in meditation is the best choice to get best results.

**Precautions**

1. Kapha dosha prakriti person should do it for small duration.

**Pran Mudra**

The word “Pran” means life. The practice of Pran Mudra strengthens all the five pranas in our body.

**Fig.22.7: Pran Mudra****Method**

1. Sit in any meditative pose.
2. Touch the tips of little finger, ring finger and thumb with slight pressure.



**Benefits**

1. It is useful to increase the pranic energy and immunity.
2. It is also useful in intolerance of heat stress, inflammatory disorders, sleeplessness, high blood pressure, burning in the mouth, throat and stomach.

**Duration**

Regular practice of 30-45 minutes is enough to get good result. It can be practised at any time or any position but in the morning hours is the best time and a break can be taken in between the 45 minutes practice.

**Precautions**

1. In cough and cold condition it should be done only for short duration.

**Varun Mudra**

Varun mudra is to increase water element in the body so it is also called as a jal-vardhak mudra.

**Method**

1. Sit in any meditative pose.
2. Touch the tips of the little finger & thumb with slight pressure.



Fig.22.8: Varun Mudra

**Benefits**

1. Dryness of the body.
2. Skin and blood disorders
3. Dehydration

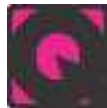
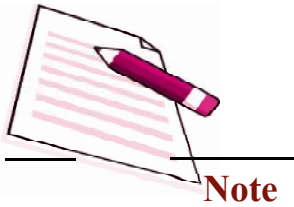
**Duration**

Regular practice of 30 minutes is enough to get good result. It can be practised at any time or any position but morning hours are the best time and a break can be taken in between the 30 minutes practice.

**Precaution**

In obesity and swelling in the body, it should not be practised.

**Note**



**INTEXT QUESTIONS 22.2**

**A. Match the Following:**

- |                  |          |
|------------------|----------|
| 1. Thumb         | a. water |
| 2. Index finger  | b. fire  |
| 3. Middle finger | c. space |
| 4. Ring finger   | d. earth |
| 5. Little finger | e. air   |

**B. Fill in the blanks with the appropriate word:**

- ..... is the most popular Mudra among hand mudras.
- .....helps to balance the air inside the body.
- In Gyan Mudra the tip of ..... and .....finger are joined.
- Joining the tip of the ring finger on the base of the thumb is practiced in.....Mudra.
- ..... and ..... Mudras are used for weight loss and obesity.
- .....Mudra is beneficial for a lean and thin person.
- Varun Mudra is beneficial in ..... and .....
- To get maximum benefits of any Mudra minimum of ..... Minutes practice is necessary.

**22.2.1 Asan Mudra/Postural Mudra**

Mudras which are performed as postures are called Asan mudra.

**Maha Mudra**



**Fig.22.9: Maha Mudra**





**Method**

1. Sit on the floor with legs stretched in front. Fold the left leg and press the perineum with the left heel.
2. The right leg remains stretched in front throughout the practice.
3. Bend forward and hold the big toe of the right leg with the hands. Exhale while bending forward.
4. Raise the head upwards and let both eyes' sight to be on the centre of eyebrows. Inhale slowly and deeply.
5. Hold the breath inside and perform Moola Bandha.
6. Contract the throat so that air does not escape from the lungs.
7. Maintain this position with breath inside (Antar Kumbhaka) as long as you are comfortable.
8. This is one round. One can practice from 3 rounds to 12 rounds.
9. To release the pose, exhale slowly and bring the head to normal position. Stretch out the legs, relax the body and breathe normally.
10. The same method should be followed with other leg.
11. The attention remains at the centre of eye-brows during the practice.

**Benefits**

1. Maha Mudra improves digestion, colic and cures the disorders of the stomach.
2. It helps to cure skin disorders.
3. It can neutralize the effect of toxins in the body.
4. It generates peace and helps in increase in concentration.
5. This practice makes the spine straight and enables the pranic energy to go between Mooladhara and the Vishuddhi chakra.

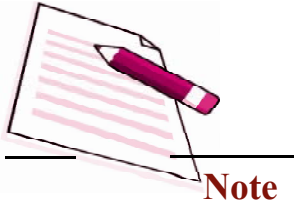
**Precautions**

1. Avoid during pregnancy, high blood pressure, disorders of the eye & heart disease.
2. Avoid in recent surgery.



**Note**



**Note**

## Vipareeta Karani Mudra



**Fig.22.10: Vipareet Karani Mudra**

### Method

1. Start with the supine position, lying on your back in a relaxed manner. Let the hands rest on the floor next to the body and breathe normally.
2. Try to raise the legs slowly to 90 degrees to the floor.
3. Now place the hands under the lower back at the waist level. Use the hands and elbows for support to raise your body up further.
4. Breath should be inside when you are raising the body to the vertical position.
5. Use the support of the hands to raise the body further up, till the whole trunk is about 45 degrees to the ground and the leg are vertical. At this stage the body weight rests on the shoulders. Hands and elbows remain to support and balance the body.
6. In the final pose the legs are 90 degrees to the floor and the trunk is about 45 degrees to the floor.
7. Breathe normally while maintaining the steady raised position.
8. While releasing the position, the breath is held inside and the body is slowly brought down to the supine position.
9. After performing Vipareeta Karani Mudra; counter asanas like Matyasana, Ushtrasana or Supta Vajrasana is performed.



### Benefits

1. It stimulates the thyroid gland.
2. It helps to balance the functions of other endocrine glands.
3. This pose helps in piles, hydrocele and hernia.
4. It enhances the function of digestive system

### Precautions

1. Avoid in menstruation, pregnancy, high blood pressure, heart diseases, eye disorders & constipation.
2. If you feel tingling sensation in feet or legs, immediately come back into the sitting position.

### Ashwini Mudra

Practising of frequent contractions & relaxations of anal muscles is called Ashwini Mudra.

### Method:

1. Sit in padmasana, siddhasana, vajrasana or sukhasana for ashwini mudra.
2. Once you get into the posture, relax for a minute, breathing freely and deeply. Then inhale fully, hold your breath, and contract the anal muscles with a 1-2 seconds interval.
3. Press your chin against the bottom of the neck, touch the palate with the tip of your tongue and start releasing your breath (exhaling), then release the mudra, and after that slowly raise your head.

### Benefits

1. It stimulates the abdomen and pelvic area including reproductive and digestive organs.
2. This simple practice can help you get rid of constipation, deals with the diseases of the rectum and haemorrhoids and can improve sexual health.

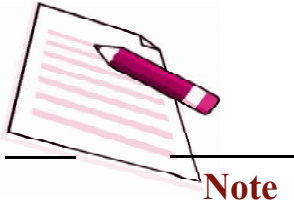
### Precaution

1. Don't do during pregnancy.
2. Don't do it after the surgeries related to anus.



### Note





### INTEXT QUESTIONS 22.3

#### A. Fill in the blanks with appropriate word:

1. Mudras which are performed as postures are called.....
2. In ..... Mudra, the attention remains at the ..... of eye-brows during the practice.
3. In final stage of vipareet karani mudra, the legs are at ....degrees and the trunk is about .... degrees to the floor.

#### B. Mark the following statements as True or False.

1. After performing vipareet karani mudra, counter asanas like matyasana, ushtrasana or supta vajrasana are performed. ( )
2. Practicing of frequent contractions & relaxations of anal muscles is called Ashwini Mudra. ( )
3. Vipareet Karani Mudra improves sexual health. ( )

#### 22.2.2 Mukh Mudra

Mudras which are performed with face are called Mukh mudra. Shambhavi, kaki comes under Mukh Mudra.

#### Shambhavi Mudra (The Eyebrow Center)

Gazing at the eyebrow centre, sitting in any meditative pose with gyan mudra is known as Shambhavi mudra. Shambhavi mudra is considered one of the most important mudras for meditation.



Fig.10.11: Shambhavi Mudra



**Method**

1. Sit in any meditative asana like Padmasana, Siddhasana, Sukhasana or Swastikasana.
2. Keep palms on the knees with Gyan or Chin mudra.
3. Roll both the eyes upwards and try to see at the eyebrow center. It forms a kind of V-shaped line at the center.
4. Concentrate the eyes on center region of the V-shaped line.
5. Maintain this position as long as you can. The eye muscles will start to pain after few seconds or within few minutes. Relax the eyes and bring it back to the normal position. Rest for some time and try again. With regular practice, one can hold this position for longer duration.
6. Breathe normally during the practice. As you proceed, your breath will slow down and become more stable.

**Benefits**

1. It helps in reaching the higher states of consciousness.
2. It stabilizes the mind and increases concentration.
3. It helps to strengthen the eye muscles.
4. It activates the Ajna chakra

**Precaution**

1. Do not practice if there is glaucoma or in any eye problems.

**Kaki Mudra**

In this mudra the face appears like a crow, hence it is known as Kaki mudra.

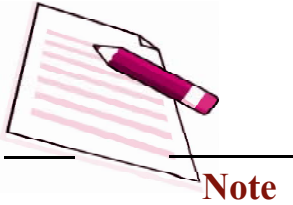


Fig.22.12: Kaki Mudra



**Note**



**Method**

1. Sit in any comfortable meditative pose with erect spine.
2. Close the eyes & relax your body.
3. Keep both hands on knees with gyan mudra.
4. Then open your eyes and focus on tip of the nose.
5. Make a beak of lips by rolling the tongue and inhale slowly with this beak.
6. When lungs are full hold the breath as long as possible (Antar Kumbhak) and close the eyes.
7. Then exhale slowly through the nose.
8. Practice this for at least two to three minutes. Slowly increase the duration.

**Benefits**

1. Strengthen the face
2. Strengthens the nasal passage
3. Strengthens the respiratory system
4. Refreshes the skin
5. Cleans the Chakras

**Precaution**

- Do not practise in polluted environment
- Do not practise in glaucoma, low blood pressure, cough or cold.
- In recent eye operation one should consult an expert before practising.

**INTEXT QUESTIONS 22.4****A. Fill in the Blanks with appropriate words:**

1. Shambhavi and Kaki Mudra comes under ..... Mudra.
2. Gazing at the eyebrow centre, sitting in any meditative pose with gyan mudra is known as.....
3. In ..... Mudra the face appears like a crow.





## 22.3 MEANING OF BANDHA

The bandhas are an important part of asana practice. The Sanskrit word Bandha means to hold, tighten or lock. The bandhas aim to lock the Pranas in particular areas and redirect their flow into *Sushumna Nadi* for the purpose of spiritual awakening. Bandhas are the ‘body locks’ that are held by tightening and lifting of certain muscles of the body.

There are three main bandhas: **Jaladhara bandha** (throat), **Uddiyana bandha** (abdomen) and **Moola bandha** (located in the perineum).

**Maha bandha** is the combination of all three bandhas together.

### Importance

1. These four techniques allow the practitioner to control different nerves and organs of the body.
2. They also affect the chakras and release spiritual power by allowing Kundalini flow up to Sushumna Nadi.

### Jalandhara Bandha – The Chin Lock

Jalandhara bandha is one of the energetic locks used in a Hatha Yog practice. It is also known as ‘chin lock’. The Sanskrit meaning of Jala is ‘web’ or ‘net’ and dhara means ‘holding’. It is performed by extending the neck and elevating the sternum before dropping the head so that the chin may rest on the chest.



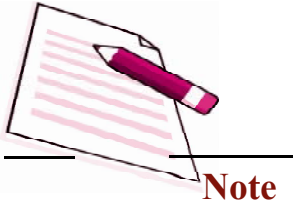
Fig.22.13: Jalandhar Bandha



### Note





**Note****Method**

1. Sit erect in meditative pose like Padmasana or Siddhasana.
2. Place the palms on the knees and make sure that the knees are touching the floor.
3. Close your eyes and relax the body. Breathe normally.
4. Now inhale slowly and deeply and then hold the breath.
5. Bend the head forward so that the chin touches the chest between the two collar bones notch/pit of the sternum.
6. Straighten the arms and press the knees down with the palms to create a kind of locked position. The shoulders are slightly forward to make sure the arms stay locked.
7. Hold this position as long as you are comfortable. Remember that the breath is held inside. Beginners should hold the breath for just a few seconds. Later it can be increased to a minute or more depending on your capacity.
8. To release the lock bend the arms, raise your head and exhale out. Come back to the straight position and take a few normal breaths.
9. Repeat the process as many times as you feel comfortable.

**Benefits**

1. It stimulates the thyroid and the para thyroid glands. Thus regulates the body metabolism.
2. Jalandhara Bandha helps to activate the throat (Vishudhi) chakra.
3. It prevents the Prana Shakti from moving upwards.
4. It increases the blood flow in the brain.
5. Jalandhara Bandha is one of the three yogic locks that have to be mastered before attempting the Maha Bandha or the triple lock.

**Precautions**

1. Avoid in high or low blood pressure, heart diseases.
2. Avoid in stiffness of neck, cervical spondylitis & spondylosis.
3. Never force your chin to touch the notch/pit of sternum.



## Uddiyana Bandha- The Flying Up Lock

The word Uddiyana in Sanskrit means - to fly up, or to rise up. This 'flying up lock' means- flying upwards of one's internal energy i.e. Prana.



Fig.22.14: Uddiyana Bandha

### Method

1. Sit erect in any meditative asan and keep palms on the knees. Relax whole body by closing the eyes.
2. Inhale slowly and gradually then exhale completely so that abdomen moves inwards as much as possible with one breath.
3. Then perform Jalandar bandha.
4. Upper abdomen moves inwards underneath the rib cage with chest moving outwards is called Uddiyana bandha.
5. Hold this position comfortably as long as possible.

### Benefits

1. It stimulates digestive system and helps in constipation.
2. It stimulates the pancreas and is helpful for diabetes.
3. It strengthens the abdominal muscles & immune system.
4. Balances the mind and anger and depressive mood.

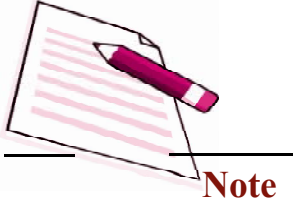
### Precautions

1. Avoid in high blood pressure, heart disease, hernia & glaucoma.
2. Avoid in menstruation, pregnancy, duodenal & peptic ulcers.



### Note





### Moola Bandha- The Root Lock

The Sanskrit word Moola means 'base, root, and bottom'; Bandha means 'restrain, hold, lock or closed'. It is also known as 'root lock'. It is related to the subtle body. Its physical counterpart is the perineum muscle, which is located between the anus and the genitals and moves in an upward direction.

#### Method:

1. Sit erect in Siddhasana, pressing the perineum with the left heel.
2. Look straight ahead and take a deep breath.
3. Exhale slowly and as the abdomen contracts, close the anal sphincters tightly & continuously and then draw them upwards.
4. Hold the contraction for five to ten seconds or as long as possible without discomfort.
5. Inhale slowly and relax the anal muscles slowly.

#### Benefits

1. It tones the digestive system, reproductive organs, and perineum and can help women with painful periods.
2. Moola bandha essentially prepares for a spiritual awakening by activating root chakra.

#### Duration

Perform five turns in the beginning and increase by one turn every week up to a maximum of ten turns for gaining the maximum amount of physical benefit. Relax for about five seconds between the contractions.

#### Precautions

1. Avoid in high blood pressure, heart disease or any major diseases.
2. Should not be done in case of bleeding per rectum.



### INTEXT QUESTIONS 22.5

#### A. Fill in the Blanks with appropriate words:

1. Bandhas are the ..... that are held by tightening and lifting of certain muscles of the body.



2. The three main bandhas are.....and .....
3. Jalandhar Bandh is also known as.....
4. Thyroid and parathyroid glands are stimulated by.....
5. In.....bandha upper abdomen moves inwards underneath the rib cage with chest moving outwards.

### B. Mark the following as True or False

1. Uddiyan bandha can be practised in duodenal and peptic ulcer disease. ( )
2. Moola Bandha is also known as the root lock. ( )
3. Maha bandha is the combination of any two Bandha together. ( )



### WHAT YOU HAVE LEARNT

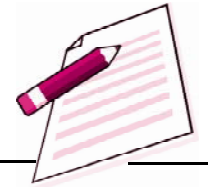
In this lesson we have learnt:

- Practice of Mudra and Bandha is considered to be more effective than practice of asana and Pranayam.
- Mudra is a symbolic gesture used in yog. There are various types of mudras and each type has a specific effect on the body and mind.
- Touching the fingers of hand in different positions is known as Hast Mudra. In Hast Mudra each finger of the hand represents each element.
- Mudras which are performed as postures are called Asana mudra. This includes Maha mudra, Vipareet Karani and Ashwani Mudra.
- Mudras which are performed with face are called Mukh mudra. Shambhavi mudra, kaki mudra comes under Mukh Mudra.
- The bandhas are an important part of asana practice. Bandhas are the 'body locks' that are held by tightening and lifting certain muscles. There are three main bandhas: **Jaladhara bandha** (throat), **Uddiyana bandha** (abdomen) and **Moola bandha** (located in the perineum). **Maha bandha** is the combination of all three bandhas together.



### TERMINAL QUESTIONS

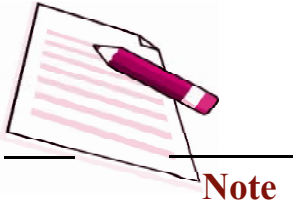
1. Define Mudra.



### Note



## Yogic Practices



2. Which mudra is called King among all the mudras?
3. Write the benefits of Vipareet Karni mudra.
4. Explain the method of Maha mudra.
5. What is meant by Shambhavi mudra?
6. Explain the meaning of Bandha.
7. Describe the benefits of Uddiyana Bandha.
8. How many types of bandhas are included in Mahabandha? Explain.
9. Explain the precautions of Jalandhar Bandha.
10. List the benefits of Moola Bandha.



## ANSWERS TO INTEXT QUESTIONS

## 22.1

## A.

1. Mudra
2. Hand
3. 10 and 25

## 22.2 A.

1.b 2.e 3.c 4.d 5.a

## B.

1. Gyan
2. Vayu Mudra
3. Thumb and index
4. Surya Mudra
5. Surya and Linga
6. Prithvi
7. Dryness, Dehydration of the body
8. 30-45



22.3

A.

1. Asana Mudra
2. Mahamudra, centre
3. 90, 45

B.

1. Right
2. Right
3. Wrong

22.4

A.

1. Mukha
2. Shambhavi
3. Kaki

22.5

A.

1. Body locks
2. Jalandhar, Uddiyan and Moola Bandha
3. Chin Lock
4. Jalandhar Bandha
5. Uddiyan

B.

1. Wrong
2. Right
3. Wrong



Note



# CURRICULUM PHYSICAL EDUCATION AND YOG



373enmis

## Rationale

Physical Education and Yog are integral parts of the learning process in school education system. They have crucial role in all round development of the student. Physical Education and Yog explain students about their health, safety, well being and physical activity participation in context of scientific fields such as physiology, nutrition and psychology etc. Yog is an ancient art that focuses on healthy mind in healthy body. The great saints promoted yog as a universal element that enhances the physical, mental, spiritual aspects of a human being. Worldwide recognition of yog resulted in United Nations declaring 21 June an annual International Yoga Day. As per National Curriculum Framework (NCF), 2005 & National Policy on Education 2016 report, Physical Education and yog is a part of school curriculum. The aim of education system is to build citizens who can contribute in all aspects of life; holistic development of an individual; which cannot be achieved without Yog and Physical Education program at school level. The aim of physical education is to build a healthy citizen through physical activities that may be evaluated during competitions, inter-community sports contests, internal competition, special programs at school level etc. Such activities boost cooperation, discipline, competitive spirit, democratic values, socialization, culture, national spirit, employment and peace to a child. Researches show that regular physical activity can help in reduction of several diseases and improvement in overall quality of life. Individual health is influenced by biological, social, economic, cultural and political forces which can be indicated through mortality and nutritional indicators. Physical Education develops proficiency in movement skills, physical activities and movement concepts, and acquires an understanding of body moves in students. Physical activities are a powerful medium for learning, through which students can acquire and refine personal behavioral, social and cognitive skills.

## Objectives

The main objectives of this course are:

- to appraise the courses in sports, physical education and yog.
- to understand the concept of Physical Education and yog.
- to learn origin and various paths of yog.
- to broaden the understanding of Physical, Physiological, Psychological, Social and Spiritual aspects of human beings.
- to provide an in-depth knowledge of different aspects of health, diet and nutrition





- to enhance the knowledge about health with special reference to lifestyle disorder.
- to provide knowledge and skills in Sukshma Vyayama, Assana, Pranayam, Meditation & Physical Fitness Test.
- to apprise career aspects in Physical Education, sports and yog
- to educate and inculcate ethics and values
- to educate the learners about sports competition and tournament organization.
- to educate about various sports injuries and their management.
- to promote awareness of health and wellness.
- to promote health, safety and physical activities.
- to understand allied fields of physical education and yog.

## Approach

The course has been designed to provide conceptual and practical exposure to the learners in Physical Education and Yog and related areas for creating very relevant and professional approach to Physical Education and Yog. While the course focuses on all the aspects of Physical Education and Yog. Special emphasis would be laid on the contemporary development of physical education as an academic subject. Since the nature of the subject is inter disciplinary, different areas such as sports training, diet and nutrition, test and measurement, organization and physical education and Yog for various populations such as women, children, aged persons and Children With Special needs of DIVYANG has been incorporated.

- I. The course uses a unique blend of self instructional material, personal contact programmes, audio, video programmes and emphasis on the comprehensive continuous and assessment of learners.
- II. It adopts a case study approach to expose the learners to organization of tournaments, and management of sports events.
- III. It involves the study of Physical Education and Yog through historical, cultural, and management perspectives highlighting their relevance in the Promotion of Health.
- IV. The focus is also on building an academic – industry collaboration for wider practical orientation of the learners which will help in enhancing their employability.
- V. Throughout the course Physical Education and Yoga are looked at as a resource, profession and industry.

## Eligibility Conditions

Pass certificate in Secondary Education



## Medium of Instruction

English (The course shall be translated in Hindi and regional medium)

## Duration of the Course

The duration of the course shall be one year, with a maximum of 5 years to complete the course.

## Weightage

**Theory** : 70%

**Practical** : 30%

**TMA** : 20% of Theory

## Teaching Methodology

**Theory-** Printed self learning materials with face-to-face contact sessions for academic support.

### Practical

**Assignment-** One assignment shall be administered for continuous assessment.

## Evaluation Procedure

Theory Paper 70 marks

Practical 30 marks

Tutor Mark Assignment (TMA) 20% of the Theory

**Pass Criteria** 33% in each component

## Course Structure

Distribution of Marks and Study hours for each module are as follows;

Module	Name of Module	Marks	Study Hours
1	Concept of Physical Education and Yog	10	24
2	Dimensions of Physical Education and Yog	14	33
3	Holistic Health	14	33
4.	Physical Education and Sports Sciences	16	39
5.	Yogic Practices	16	39
	<b>Total</b>	<b>70</b>	<b>168</b>



## Practical

No.	Content	Marks	Study Hours
1	Measurement of Health related Fitness Tests( All the Components)	5	12
2	Measurement of Physical and Motor Fitness Test (All the Items)	5	12
3	Skills of any Team/ Individual Game	5	12
4	<b>Yog Practical-I</b> <ul style="list-style-type: none"> <li>Sukshma Vyayama</li> <li>Asana (Surya Namaskar, Forward Bending, Backward Bending, Inverted Poses, Twisting, Balancing, Standing)</li> </ul>	5	12
5	<b>Yog Practical-II</b> <ul style="list-style-type: none"> <li>Shatkarma ( Jal Neti, Kunjal, Kapal-bhati, Tratak)</li> <li>Pranayam</li> <li>Mudra</li> <li>Bandh</li> <li>Meditation</li> </ul>	5	12
6.	Record File & Viva	5	12
	<b>Total</b>	<b>30</b>	<b>72</b>

## Course Description

### Module - 1: Concept of Physical Education and Yog

**Weightage:** 10 Marks      **Study Hours:** 24 Hours

### Approach

This module is developed to acquaint learners with the basic concept and historical development of Physical Education and Yog. The learner would be able to understand ethical values inculcated through physical education. They will be able to learn the importance of wellness and how physical fitness and wellness can be promoted. They will be able to learn various career avenues available in physical education & yog.



1. **Introduction and Historical Development**
2. **Ethics and Values**
3. **Physical Fitness & Wellness**
4. **Career Aspects**

### **Module - 2: Dimensions of Physical Education and Yog**

**Weightage: 14 Marks      Study Hours: 33 Hours**

#### **Approach**

This module is designed to familiarize the learner with various dimensions of physical education and yog. They will be able to learn how physical education and yog can help to promote physical aspect. They will be able to learn the physiological changes and adaptations. The learner will be able to learn the psychological benefits of physical activities and understand the social values as well as understand the spiritual aspects through yog.

5. **Physical and Physiological aspects**
6. **Psychological aspects**
7. **Social aspects**
8. **Spiritual aspects**

### **Module - 3: Holistic Health**

**Weightage: 14 Marks      Study Hours: 33 Hours**

#### **Approach**

This module is designed to make learner understand the spectrum of health and role of diet and nutrition for promoting health. He will be able to learn complexity of obesity and disease management, awareness about lifestyle disorder. The learner will be able to understand the conceptual framework of the school health program.

9. **Introduction to health**
10. **Diet and Nutrition**
11. **Awareness of Lifestyle Disorders**
12. **School Health Programme**



## **Module - 4: Physical Education and Sports Sciences**

**Weightage: 16 Marks      Study Hours: 39 Hours**

### **Approach**

This module is developed to acquaint learners with the practitioners of the physical education program and sports. The learner would be able to understand various sections of population practising sports. They will be introduced to scientific process of sports training and performance enhancement, procedure and talent and sports performance. They will be able to understand different aspects of organization of competition and tournament. They will be able to understand various injuries associated with sports and their management.

- 13. Physical Education for various populations**
- 14. Sports Training**
- 15. Test and Measurement**
- 16. Organization of Tournaments**
- 17. Athletic Injuries, First Aid and Safety**

## **Module - 5: Yogic Practices**

**Weightage: 16 Marks      Study Hours: 39 Hours**

### **Approach**

This module is designed to help learners understand the importance of Yoga as unification of physical, mental, intellectual and spiritual aspects of human being through various yogic practices. The learner will learn about various components of Hath yog such as Shatkarma, Asanas, Pranayams, Mudra and Bandh. They will be able to know the therapeutic aspects of yogic practices in preventing and curing various diseases.

- 18. Hath Yoga**
- 19. ShatKarma**
- 20. Asana**
- 21. Pranayama**
- 22. Mudra and Bandha**



## Learning Outcomes

### Physical Education and Yog

#### Lesson-1 Introduction and Historical Development

After studying this lesson, the learner will be able to:

- explain the meaning and importance of physical education.
- recognize different ages and period in historical development of Physical education.
- become familiar with concept of yog and discuss its historical development.
- list need and importance of yog- physically, socially and mentally.

#### Lesson -2 Ethics and Values

After studying this lesson, the learner will be able to:

- explain the concept of sportsmanship.
- describe ethics in sports and role of ethics in physical education and sports and role of physical education teacher in maintaining the code of ethics in sports.
- outline the Olympic values and different ways of incorporating Olympic values among children.
- recognize how to develop social and personal ethics through yog.

#### Lesson -3 Physical Fitness & Wellness

After studying this lesson, the learner will be able to:

- describe the concept to physical fitness with its importance in life.
- differentiate the type of Physical fitness and its components.
- explain the concept of wellness and enlist the dimensions of wellness.
- recognize the health benefits of yog



#### **Lesson -4 Career Aspects of Physical Education**

After studying this lesson, the learner will be able to:

- explain the different career opportunities in Physical Education.
- list the different courses and universities available for Physical Education.
- recognize the qualities of a Physical Education Teacher.

#### **Lesson -5 Physical and Physiological Aspects of Physical Education**

After studying this lesson, the learner will be able to:

- distinguish between the isometric, isotonic and iso-kinetic exercises and its effects on our body.
- explain the short-term effect and long-term effect of exercise on the muscular system.
- discuss the effect of exercises on respiratory rate, tidal volume, rate of gas exchange, lung volume, pulmonary diffusion, residual volume in function of respiratory system.
- describe the physiological aspects of yoga that can be observed in shudhi kriyas, pranayama and asanas.

#### **Lesson -6 Psychological Aspects**

After studying this lesson, the learner will be able to:

- recognize the different psychological characteristics due to physical, mental, social and cognitive changes in the adolescent age.
- develop a sense of personality, learning and its stages and also intrinsic and extrinsic motivation.
- explore the psychological factors and its effects on the performance of an athlete and how it can be improved through sports.
- identify the emotional and psychological impacts of yoga and its benefits.

#### **Lesson -7 Social Aspects**

After studying this lesson, the learner will be able to:

- learn micro and macro level of concern in sports socialization and its effects on society.





- imbibe the basic components of integration through sports which helps in development of national integration.
- identify the social factors that affect the performance of an athlete.
- recognize the effect of yog on holistic wellness and social well being of an individual.

### **Lesson -8 Spiritual Aspects**

After studying this lesson, the learner will be able to:

- recognize the concept of inner awareness
- identify the importance of mantra chanting
- experience the wisdom of Ashtang yog
- describe the concept of Meditation

### **Lesson -9 Introduction to Health**

After studying this lesson, the learner will be able to:

- explain the concept of Health
- outline the different dimensions of Health
- illustrate the principal of Health in day to day life
- recognize the factors that affect their life.
- acquire knowledge about yogic concept of health.

### **Lesson -10 Diet and Nutrition**

After studying this lesson, the learner will be able to:

- describe the concept of diet and nutrition and the role of food choices in determination of health and durability of the individual.
- differentiate between macro and micro nutrients and their requirements in our body.
- define and explain the exact meaning of balanced diet.
- explain the yogic concept of diet and what is a good diet according to this concept.
- classify the three different types of yogic diet.



### **Lesson -11 Awareness of Lifestyle Disorders**

After studying this lesson, the learner will be able to:

- recognize the concept of quality of life and how does lifestyle affect the quality of life.
- classify the dimensions of quality of life and physical and psychological disorders affecting the quality of life.
- illustrate the management skills of lifestyle disorders and role of yoga in day today life.
- identify the importance of yog in our day to day life.

### **Lesson -12 School Health Program**

After studying this lesson, the learner will be able to:

- become familiar with the concept of school health programs and its main objectives along with its compulsion and evolution.
- outline the aspects of school health program and identify the features of health services, healthy environment and health education.
- identify the members of school health committee and their respective responsibilities.
- illustrate basic yogic practices for school children.

### **Lesson -13 Physical Education for various Populations**

After studying this lesson, the learner will be able to:

- outline the effect of physical activities for growth and development of children and identify the exercises for various different age groups of children.
- discuss the need of physical exercises and activities for especially abled people in the society.
- explain the benefits of regular exercises for women in day today life.
- differentiate between moderate and vigorous exercises designed for different adults and their needs.

### **Lesson -14 Sports Training**

After studying this lesson, the learner will be able to:

- recognize the concept of sports training and its principles.



- identify the various components of physical fitness and sports training.
- differentiate between aerobic and anaerobic sports training methods and its requirements.

### **Lesson -15 Test and Measurement**

After studying this lesson, the learner will be able to:

- list the benefits of test and measurement in field of physical education and sports.
- recognize the need and importance of test and measurement and its contribution to the evaluation process.
- list the components physical fitness.

### **Lesson -16 Organization of Tournaments**

After studying this lesson, the learner will be able to:

- list the various types and methods of tournaments .
- differentiate between Intramural and Extramural tournaments.
- learn to organize a sports event and the preparations required for the organization of the sports events.
- list and draw the different types of fixtures used in organizing sports events.

### **Lesson -17 Athletic Injuries, First Aid and Safety**

After studying this lesson, the learner will be able to:

- explain the anatomy of athletic injury and classification of injuries in sports on basis of its nature and location.
- outline the principles of first aid and common causes of injuries.
- illustrate the preventive measures of athletic injuries.
- learn safety precautions at school, home, road and sports ground.

### **Lesson -18 Hath-Yog**

After studying this lesson, the learner will be able to:

- explain the concept of Hath-Yog.
- recognizes different ages and period in historical development of Hath- Yog
- outline the importance of Nadis and chakras
- list the benefits of Hath- Yog



### **Lesson -19 Shat-Karma**

After studying this lesson, the learner will be able to:

- recognize the meaning of Shat- Karma
- identify the various components OF Shat – Karma
- acquire shat karma skills to detoxification of body
- explore the benefits and precaution of shat karma

### **Lesson -20 Asana**

After studying this lesson, the learner will be able to:

- recognize the concept of Asana and its importance in day today life.
- explain the preparatory practices
- illustrate Surya namaskar
- differentiate forward bending, back bending and inverted bending asanas.
- list the twisting and balancing asanas.

### **Lesson -21 Pranayama**

After studying this lesson, the learner will be able to:

- recognize the concept of pranayama and its importance in day today life.
- classify the pre pranayama activities
- identify the various components of pranayam.
- demonstrate various pranayam
- progression of pranayama to meditation

### **Lesson -22 Mudra and Bandha**

After studying this lesson, the learner will be able to:

- describe the meaning and importance of Mudra
- recognize the different types of Mudras.
- explain the meaning and importance of bands.
- identify the types of bands and its importance.



# PHYSICAL EDUCATION AND YOG (373)

## Question Paper Design

**Subject : Physical Education and Yog**

**Level : Senior Secondary**

**Maximum Marks : 70**

**Duration : 3 Hrs.**

### 1. Weightage to Objectives

Objective	Marks	Percentage
Knowledge	18	25
Understanding	31	45
Application & Skill	21	30
<b>Total</b>	<b>70</b>	<b>100</b>

### 2. Weightage of Questions

Type of Questions	No. of Questions	Marks of Each Question	Marks Allotted
Long Answer	4	6	24
Short Answer	5	4	20
Very Short Answer	10	2	20
Multiple Choice Questions (MCQ)	6	1	6
<b>Total</b>	<b>25</b>		<b>70</b>

### 3. Weightage to Major Content Areas

Module No.	Name of the Module	Marks	Study Hours
1.	Concept of physical education and Yog	10	24
2.	Dimensions of Physical Education and Yog	14	33
3.	Holistic Health	14	33
4.	Physical Education and Sports Sciences	16	39
5.	Yogic Practices	16	39
	<b>Total</b>	<b>70</b>	<b>168</b>

### 4. Difficulty Level

	Easy	Average	Difficult	Total
Weightage	25%	45%	30%	100%
Marks Allotted	18	31	21	70

*Physical Education and Yog*





- (c) The bone has fragmented into several pieces
- (d) The bone breaks through the skin
7. Explain the meaning of physical education. 2
  8. Assess the role of physical teachers to strengthen the ethical values in the education. 2
  9. Highlight any two features of school health services. 2
  10. Analyse the concept of meditation.  $2 \times 1 = 2$
  11. Highlight the diseases related to physical and psychological disorders. 2
  12. Assess the role of sports training in achieving maximum efficiency. 2
  13. How does participation in a tournament prove a player's capabilities? 2
  14. Explain the difference between 'Jal Neti' and 'Sutra Neti'. 2
  15. Explain the importance of 'Pranayam'. 2
  16. Highlight any four benefits of Surya Mudra. 2
  17. Describe any four values that are learnt through sports.  $4 \times 1 = 4$
  18. Examine the importance of cognitive stage of learning. 4
  19. Explain any four functions of the foods.  $4 \times 1 = 4$
  20. Explain any four basic components which make an athlete fit for sports.  $4 \times 1 = 4$
  21. Evaluate any four benefits of 'Hath Yog'. 4
  22. Describe any six steps of Patanjali Yog.  $6 \times 1 = 6$
  23. Describe any three types of nutrients with examples for each.  $3 \times 2 = 6$
  24. Explain any six needs of test and measurement.  $6 \times 1 = 6$
  25. Classify the benefits given below under the three bandhas-  $3 \times 2 = 6$ 
    - i) Jaladhara Bandha
    - ii) Uddiyana Bandha
    - iii) Moola Bandha





Benefits:-

- i) Stimulates the thyroid glands
- ii) Stimulates the digestive system
- iii) Balances the mind and anpey mood
- iv) Tones the reproductive system
- v) Prepares for a spritual awaking
- vi) Increases the blood flowing brain



# PHYSICAL EDUCATION AND YOG

## Marking Scheme

Q. No.	Expected value points	Distribution of Marks	Total Marks
1.	(b) (1948)	1	1
2.	(b) Showing the best behaviour at all times	1	1
3.	(c) Motor skill development	1	1
4.	(d) Self centred	1	1
5.	b) Tenclons and muscells	1	1
6.	d) The bone breaks through the skin	1	1
7.	Phhysical education is the combination of two words - physical and education. The word physical refers to body and indicates bodily characteristics. The word education means systematic instructions or training or preparation for life.  Physiccal education is a science of complete development of the individual by participating in physical activities and sports.	2	2
8.	(i) They provide training framework of sports practices. (ii) Develope the qualities of leadership through sports. (iii) Training for fair play (iv) Stimulate the educational process through sporting activities. (v) Any other.	2	2
9.	i) Periodic medical examination of the students ii) Regular medical check ups and follow up iii) Prevention of communication diseases - immunization programme iv) First Aid v) Cleanliness vi) Check up of Eye sight and Dental Health	2	2
10.	• Meditation is a process of total perception. Total conciousness and unconditional awareness by which we are trying to come closer to our higher self.  • Through meditation the practioner tries to acquire comple knowledge of his mind.	2 × 1	2



- |     |   |   |   |
|-----|---|---|---|
| 11. | <ul style="list-style-type: none"> <li>i) Physical disorders are heart related disease, cancer, respiratory disease, diabetes, hypertension etc.</li> <li>(ii) Psychological disorders include stress, peer pressure among adolescents, work load.</li> </ul>   | 2 | 2 |
| 12. | <ul style="list-style-type: none"> <li>• Sports training prepares for better performance in various sports competitions</li> <li>• Sports training enhances the physical fitness, to achieve efficiency.</li> <li>• Better training leads to more efficiency.</li> </ul>  | 2 | 2 |
| 13. | <ul style="list-style-type: none"> <li>(i) Tournament provides an opportunity to demonstrate the games skills.</li> <li>(ii) Participation in a tournament relieves the players.</li> <li>(iii) It helps the player to monitor the level off his/her performance.</li> <li>(iv) It evaluates the standard of achievement.</li> </ul>  | 2 | 2 |
| 14. | <p><b>Jal Neti</b> means cleaning of nose and its surrounding area with the help of luke warm saline water. It is performed in the morning only with empty stomach.</p> <p><b>Sutra Neti</b> is used to clean the nasal cavity with the help of a waxed cotton thread or rubber cathetre. Thread is inserted into the nose and then pulled out from the mouth. Cleaning is done by to and fro motion of the thread.</p> | 2 | 2 |
| 15. | <p>Pranayam is the one vital component Yog that directly or indirectly affects the proper functioning of different systems of the body. It provide the freedom from any harmful and negative mental conditions such as depression and anger.</p>  | 2 | 2 |
| 16. | <ul style="list-style-type: none"> <li>(i) Reduces coldness of body</li> <li>(ii) Beneficial in inactivity of thyroid glands.</li> <li>(iii) Beneficial in over weight and obesity</li> <li>(iv) Beneficial in loss of appetite</li> <li>(v) Beneficial in digestive problems.</li> <li>(vi) Cures vision or eye problems.</li> </ul>   | 2 | 2 |



17.	Components health related of physical fitness.	4×1	4
	i) Coordination of mind and body		
	ii) Health		
	iii) Respect for others		
	iv) Pursuit of Excellence		
	v) Performance in Sports.		
18.	<ul style="list-style-type: none"> <li>• It is the first stage of learning.</li> <li>• It allows the learner to develop the skill of performance as learnt during this stage.</li> <li>• It helps the learner to plan.</li> <li>• This stage allows to commit mistake as learner is slow to perform and his confidence level is also weak at this stage.</li> <li>• It prepares the learner to practice.</li> </ul>	4	4
19.	<ul style="list-style-type: none"> <li>i) Provides Energy</li> <li>ii) Helps the growth and development of body</li> <li>iii) Repairs the wear and tear in our body</li> <li>iv) Protects from diseases</li> <li>v) Any other relevant point</li> </ul>	4× 1	4
20.	Physical exercises for age group 9 to 12.	4×1	4
	i) Physical strenght		
	ii) Endurance		
	iii) Speed		
	iv) Flexibility		
	v) Coordinative abilities		
21.	<ul style="list-style-type: none"> <li>(i) It purifies the body to reach at the higher realm of conciousness.</li> <li>(ii) It is helpful in curing various diseases and problems.</li> <li>(iii) It is helpful in relaxing the mind and releases tension.</li> <li>(iv) It tones our nerves, muscles and visceral organs and makes our body and mind fit.</li> <li>(v) It helps to keep spine flexible and supple.</li> </ul>	4	4



22.	i) Yama	4×1½	6
	ii) Niyama		
	iii) Asana		
	iv) Pranayama		
	v) Pratyahara		
	vi) Dharna		
	vii) Dhyana		
	viii) Samadhi		
23.	(i) Carbohydrates - foods like cereals, potatoes, sugar etc.	3×2	6
	(ii) Fats - Ghee, Oils, Cheese		
	(iii) Proteins - All dairy products, poultry, meat, fish, eggs-soyabeen.		
24.	(i) To measure quality,, capacity, strength and weakness.	6×1	6
	(ii) To predict in advance the performance potentials.		
	(iii) To conduct research and prepare new norms and standards based on the result.		
	(iv) To evaluate the teacher, coach & trainer		
	(v) To evaluate the learners progress.		
	(vi) To motivate athletes to perform better.		
	(vii) To diagnose learning problems of an individual.		
	(viii) To find the success level of physical education programme.		
25.	i) Jaladhara Bandha - i & vi	3× 2	6
	ii) Uddiyana Bandha - ii & iii		
	iii) Moola Bandha - iv & v		

